



BAKERY

COLLECTION

**Cayuga** DISPLAYS

BFC SERIES BAKERY ISLAND SHELVING

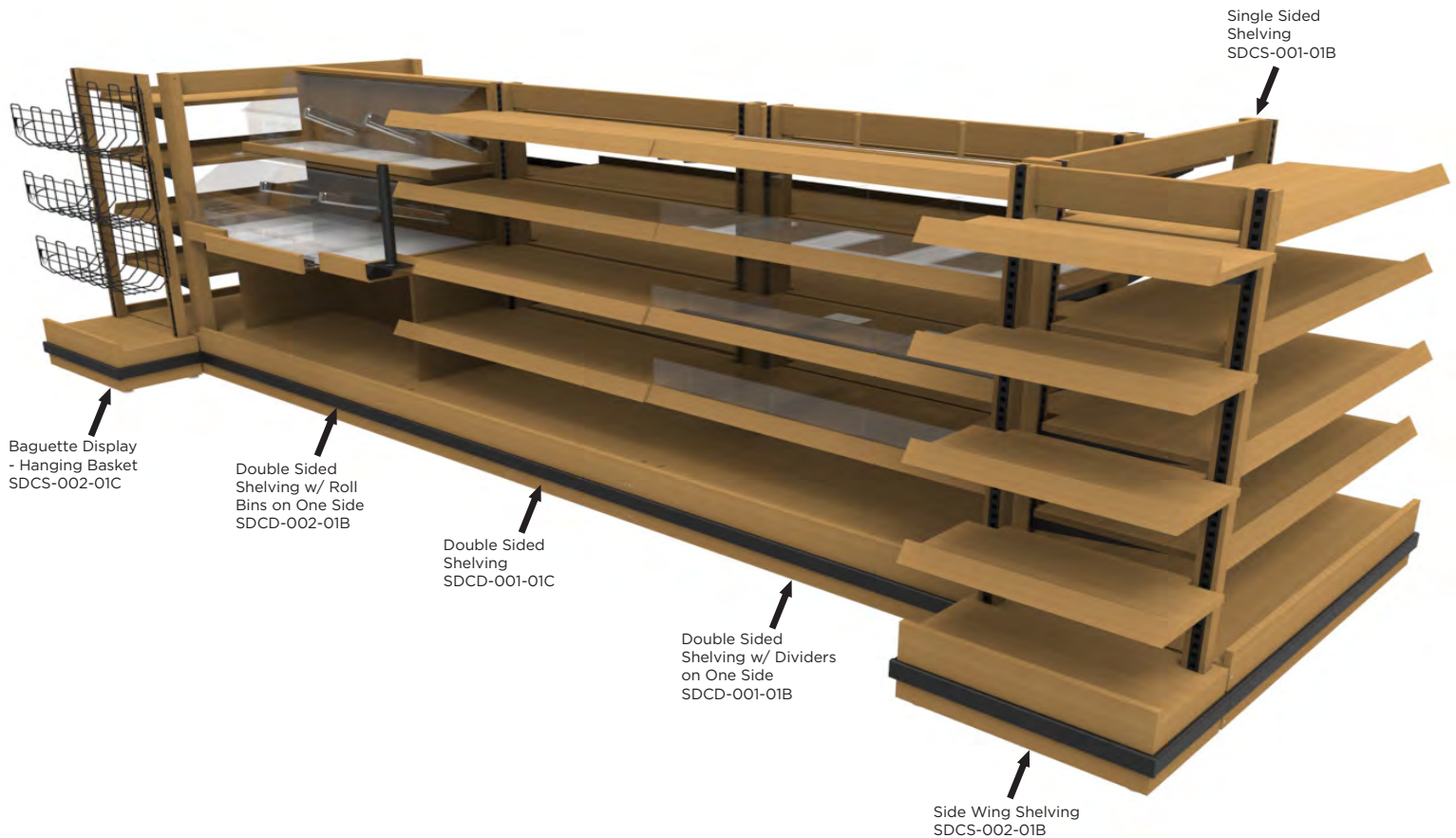

Applications

- The BFC Series is a shelving island display that allows centre units to be easily fastened together and to Single Sided Shelving
- All units come equipped with bumper
- Adjustable shelves can sit either flat or at a 15° angle
- The three Double Sided Shelving units allows for multiple combinations and line up lengths
- Bun bins are equipped with tongs, tethers and tong holders
- Double Sided Shelving w/Roll Bins has a removable crumb tray for easy cleaning
- Only the SDCD-001-01C and SDCD-001-01B are available in 3' lengths

BFC SERIES SHELVING DISPLAY - DOUBLE SIDED



MODEL	DESCRIPTION	LENGTH	DEPTH	HEIGHT
SDCD-001-01B	Double Sided Shelving w/ Dividers	47 1/2"	47 1/2"	51"
SDCD-001-01C	Double Sided Shelving	47 1/2"	47 1/2"	51"
SDCD-002-01B	Double Sided Shelving w/ Bun Bins	47 1/2"	47 1/2"	51"

FEATURES:

- Birch/maple plywood, baltic birch plywood & solid maple construction
- Non-locking casters
- 2" ABS Bumper
- Adjustable shelves - flat and 15° angle
- Shelf depths: 17"/19"

OPTIONS:

- ABS bumper (1 1/2" or 2")
- McCue bumper (1" or 2")
- See Page 47 for sign holder options
- Refer to Category C for Stain Finishes

Note: Information and specifications may change due to engineering improvements.

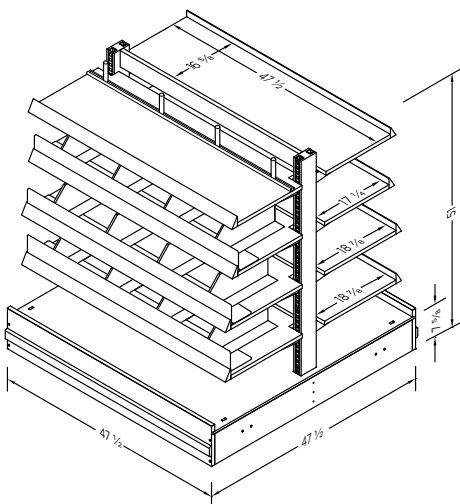

SDCD-001-01B

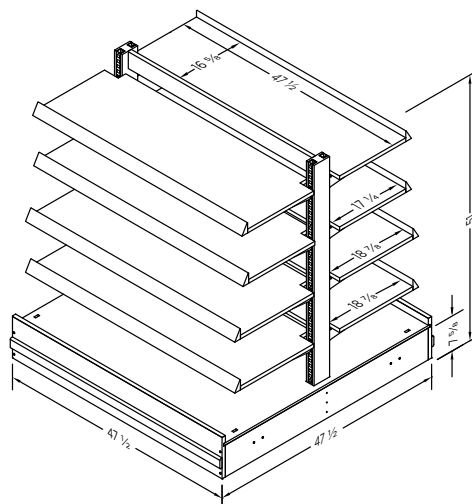

SDCD-001-01C

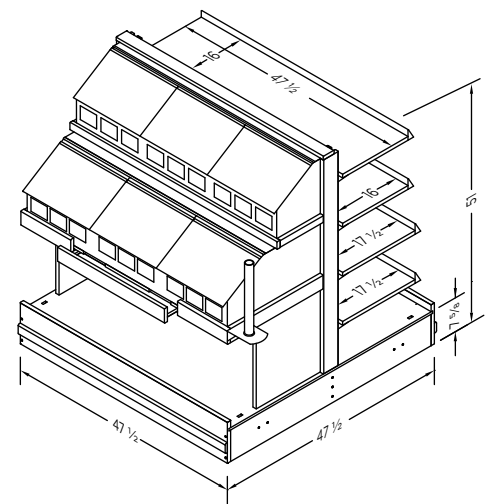

SDCD-002-01B

BFC SERIES SHELVING DISPLAY - SINGLE SIDED



MODEL	DESCRIPTION	LENGTH	DEPTH	HEIGHT
SDCS-001-01B	Single Sided Shelving	47 1/2"	24 1/8"	51"

FEATURES:

- Birch/maple plywood, baltic birch plywood & solid maple construction
- Non-locking casters
- 2" ABS Bumper
- Adjustable shelves - flat and 15° angle
- Shelf depths: 17"/19"

OPTIONS:

- ABS bumper (1 1/2" or 2")
- McCue bumper (1" or 2")
- See Page 47 for sign holder options
- Refer to Category C for Stain Finishes

Note: Information and specifications may change due to engineering improvements.

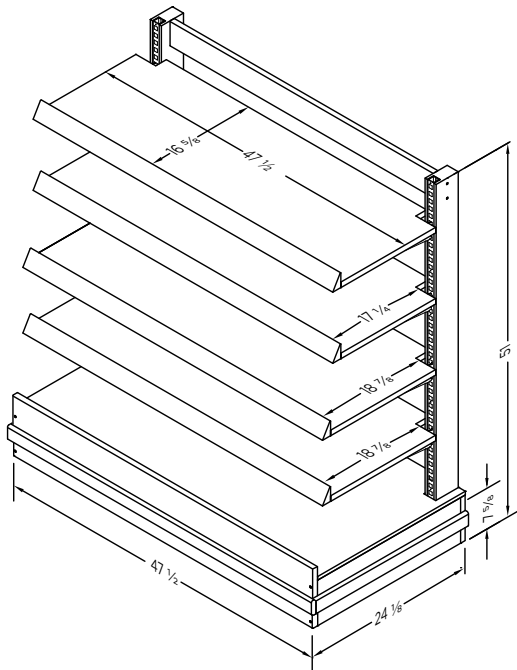

SDCS-001-01B

BFC SERIES SIDE WING SHELVING DISPLAY



MODEL	DESCRIPTION	LENGTH	DEPTH	HEIGHT
SDCS-002-01B	Side Wing Shelving	24"	13 1/8"	50 3/8"
SDCS-002-01C	Baguette Display - Hanging Basket	24"	13 1/8"	50 5/8"

FEATURES:

- Birch/maple plywood, baltic birch plywood & solid maple construction
- Levelers 2" ABS Bumper
- Adjustable shelves - flat and 15° angle
- Shelf depths: 11" or metal baguette baskets

OPTIONS:

- ABS bumper (1 1/2" or 2")
- McCue bumper (1" or 2")
- See Page 47 for sign holder options
- Refer to Category C for Stain Finishes

Note: Information and specifications may change due to engineering improvements.

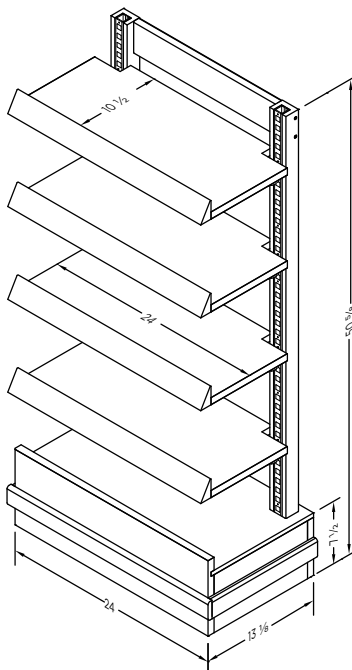

SDCS-002-01B

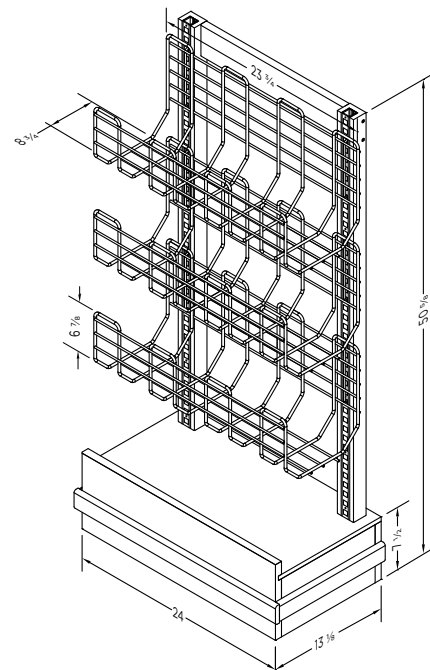

SDCS-002-01C

BGT SERIES FIXED SHELVING ISLAND DISPLAY

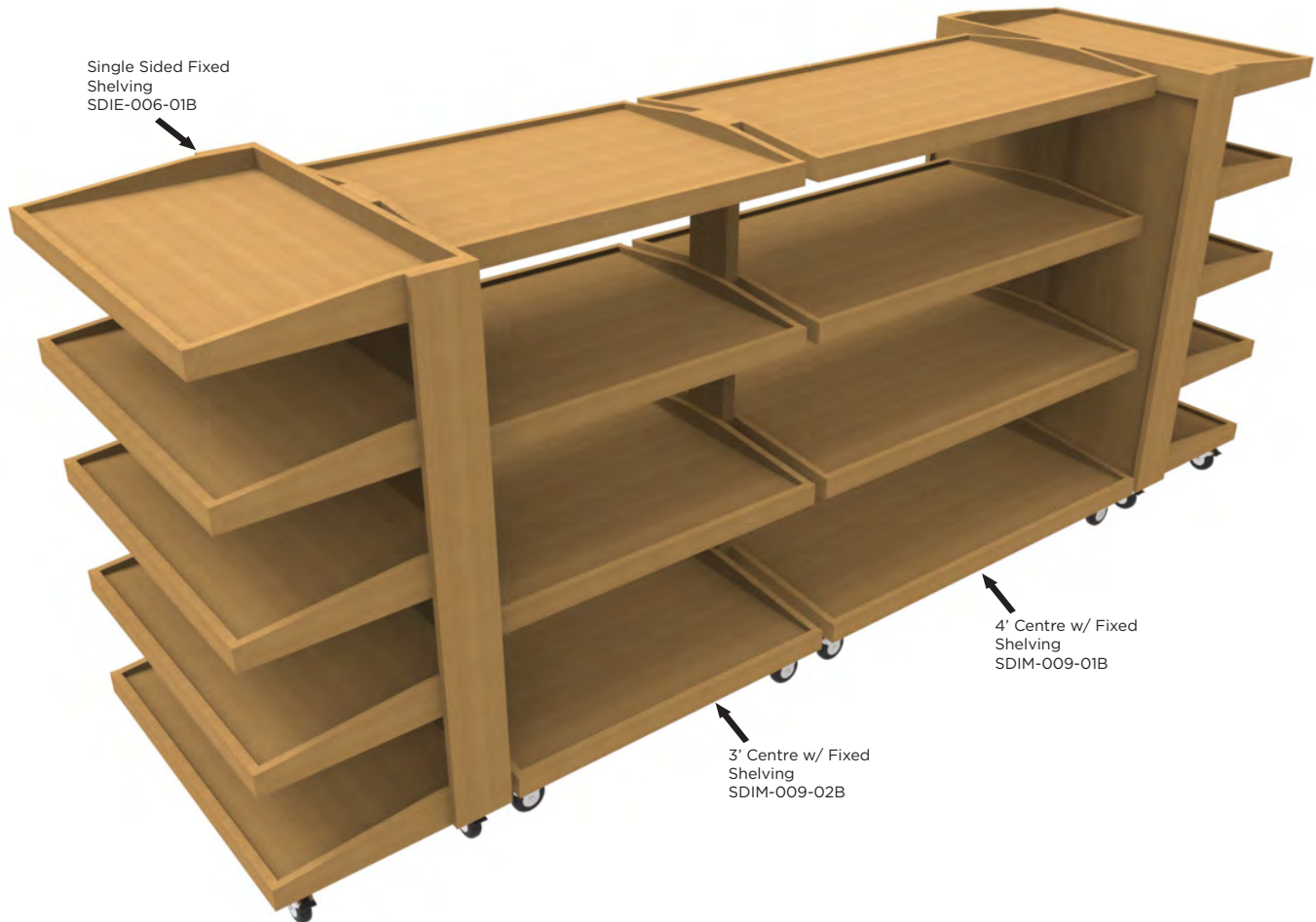

Applications

- The BGT Series is a mobile shelving island with fixed shelf heights
- Heavy duty locking casters
- Both the 3' and 4' center sections allows for multiple line up combinations
- Bumper and corner protectors available upon request

BGT SERIES SINGLE SIDED FIXED SHELVING



MODEL	DESCRIPTION	LENGTH	DEPTH	HEIGHT
SDIE-005-01B	Fixed Shelving End Cap - Large	37 1/4"	19 1/8"	60"
SDIE-006-01B	Fixed Shelving End Cap - Small	34"	19 1/8"	49"

FEATURES:

- Birch/maple plywood & solid maple construction
- Heavy duty locking casters
- Fixed height shelving

OPTIONS:

- ABS bumper (1 1/2")
- McCue bumper (1")
- Corner Protectors
- See Page 47 for sign holder options
- Refer to Category C for Stain Finishes

Note: Information and specifications may change due to engineering improvements.

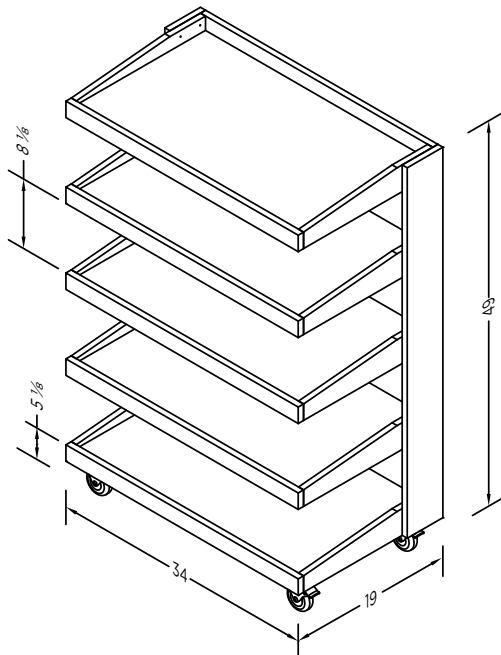

SDIE-006-01B

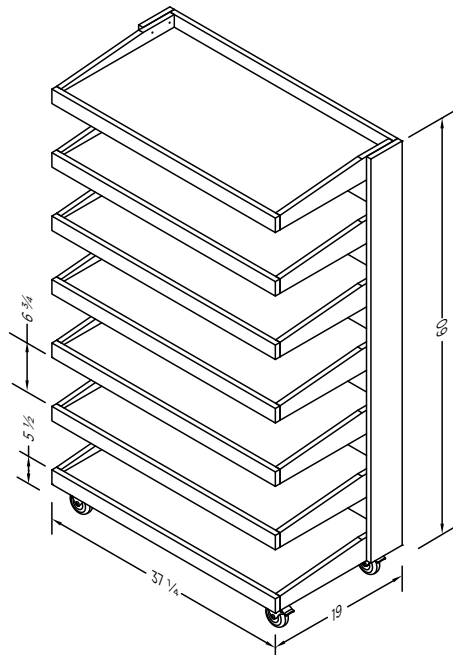

SDIE-005-01B

BGT SERIES DOUBLE SIDED FIXED SHELVING



MODEL	DESCRIPTION	LENGTH	DEPTH	HEIGHT
SDIM-009-01B	Double Sided Fixed Shelving - 4'	46 3/8"	34"	60"
SDIM-009-02B	Double Sided Fixed Shelving - 3'	34 3/8"	34"	60"

FEATURES:

- Birch/maple plywood & solid maple construction
- Heavy duty locking casters
- Fixed height shelving

OPTIONS:

- ABS bumper (1 1/2")
- McCue bumper (1")
- Corner Protectors
- Refer to Category C for Stain Finishes

Note: Information and specifications may change due to engineering improvements.

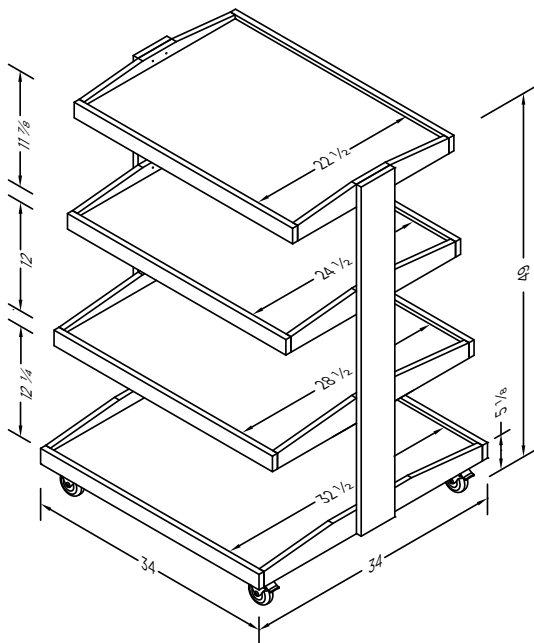

SDIM-009-02B

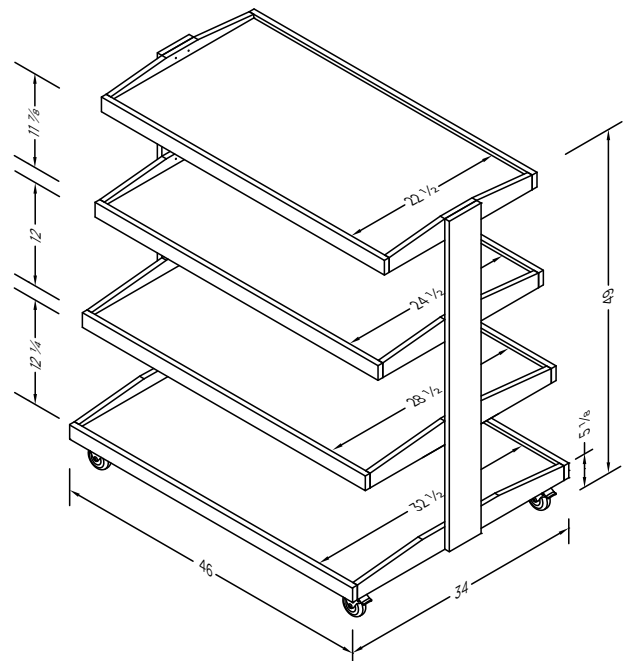

SDIM-009-01B

BCS SERIES ISLAND SHELVING DISPLAY

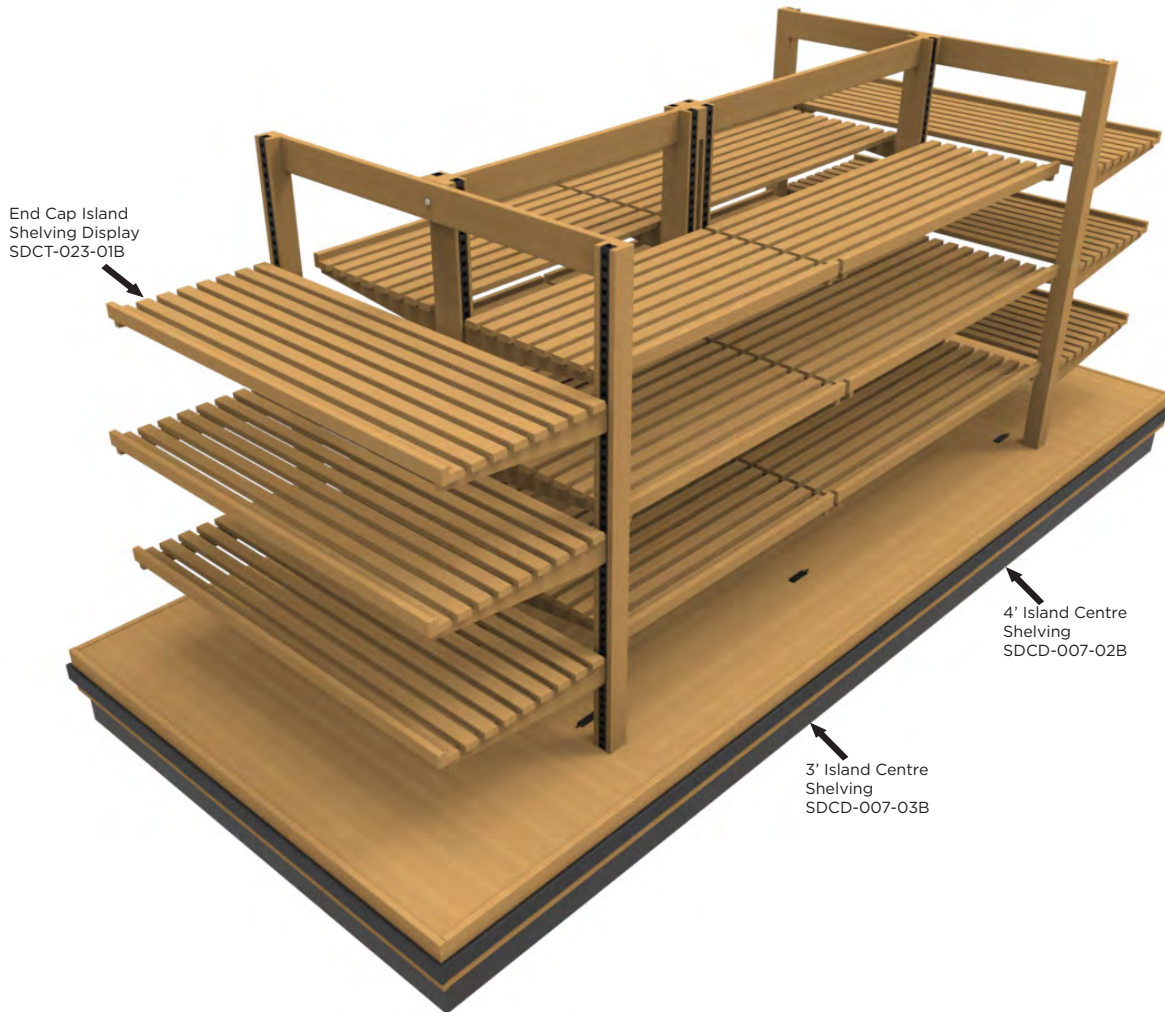

Applications

- The BCS Series is a shelving island display that allows centre units to be easily fastened together and to the end cap shelving
- All units come equipped with bumper
- Adjustable shelves can sit either flat or at a 15° angle
- Centre sections available in both the 3' and 4' lengths

BCS SERIES ISLAND SHELVING DISPLAY - END CAP



MODEL	DESCRIPTION	LENGTH	DEPTH	HEIGHT
SDCT-023-01B	Island Shelving Display - End Cap	60"	30"	61 3/8"

FEATURES:

- Birch/maple plywood & solid maple construction
- Heavy duty casters
- 2" ABS bumper
- Adjustable shelves - flat and 15° angle
- Shelf depths: 18"/21"

OPTIONS:

- ABS bumper (1 1/2")
- McCue bumper (1" or 2")
- 12", 14" and 16" deep shelves available
- See Page 47 for sign holder options
- Refer to Category C for Stain Finishes

Note: Information and specifications may change due to engineering improvements.

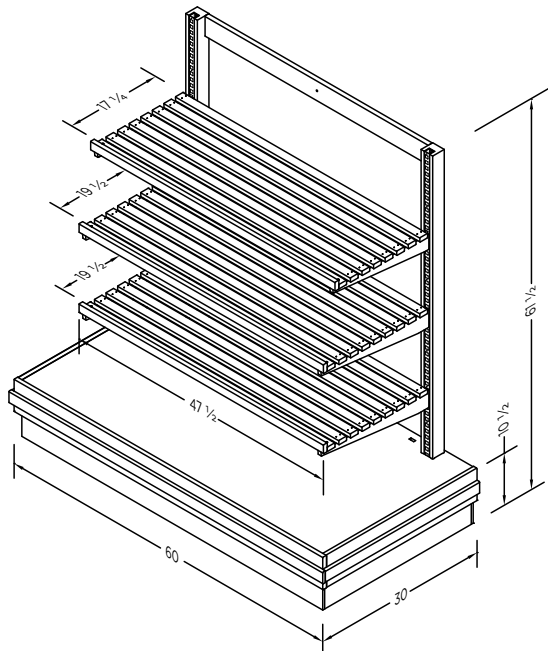

SDCT-023-01B

BCS SERIES ISLAND SHELVING DISPLAY - CENTRE



MODEL	DESCRIPTION	LENGTH	DEPTH	HEIGHT
SDCD-007-03B	Island Shelving Display - 36"	35 1/2"	60"	61 3/8"
SDCD-007-02B	Island Shelving Display - 48"	47 1/2"	60"	61 3/8"

FEATURES:

- Birch/maple plywood & solid maple construction
- Heavy duty casters
- 2" ABS bumper
- Adjustable shelves - flat and 15° angle
- Shelf depths: 18"/21"

OPTIONS:

- ABS bumper (1 1/2")
- McCue bumper (1" or 2")
- 12", 14" and 16" deep shelves available
- See Page 47 for sign holder options
- Refer to Category C for Stain Finishes

Note: Information and specifications may change due to engineering improvements.

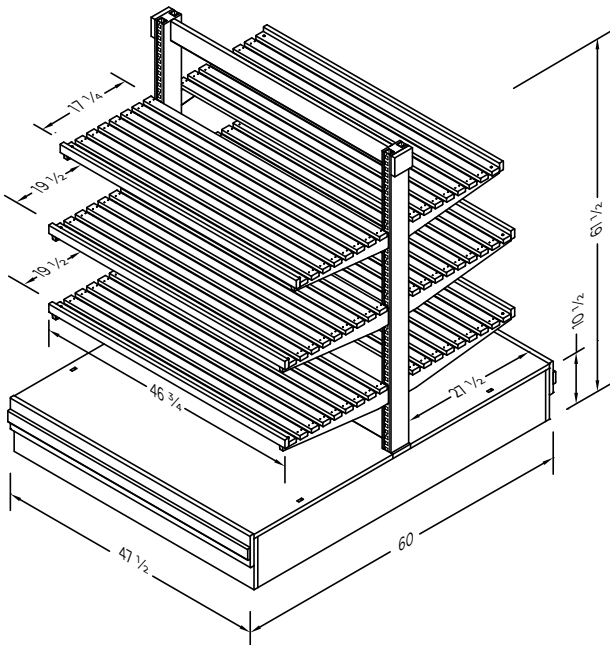

SDCD-007-02B

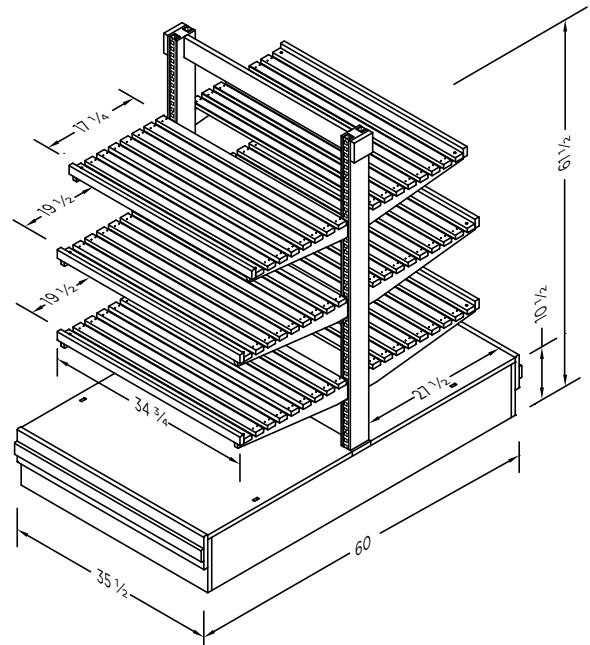

SDCD-007-03B

BFB SERIES BAKERY ISLAND SHELVING

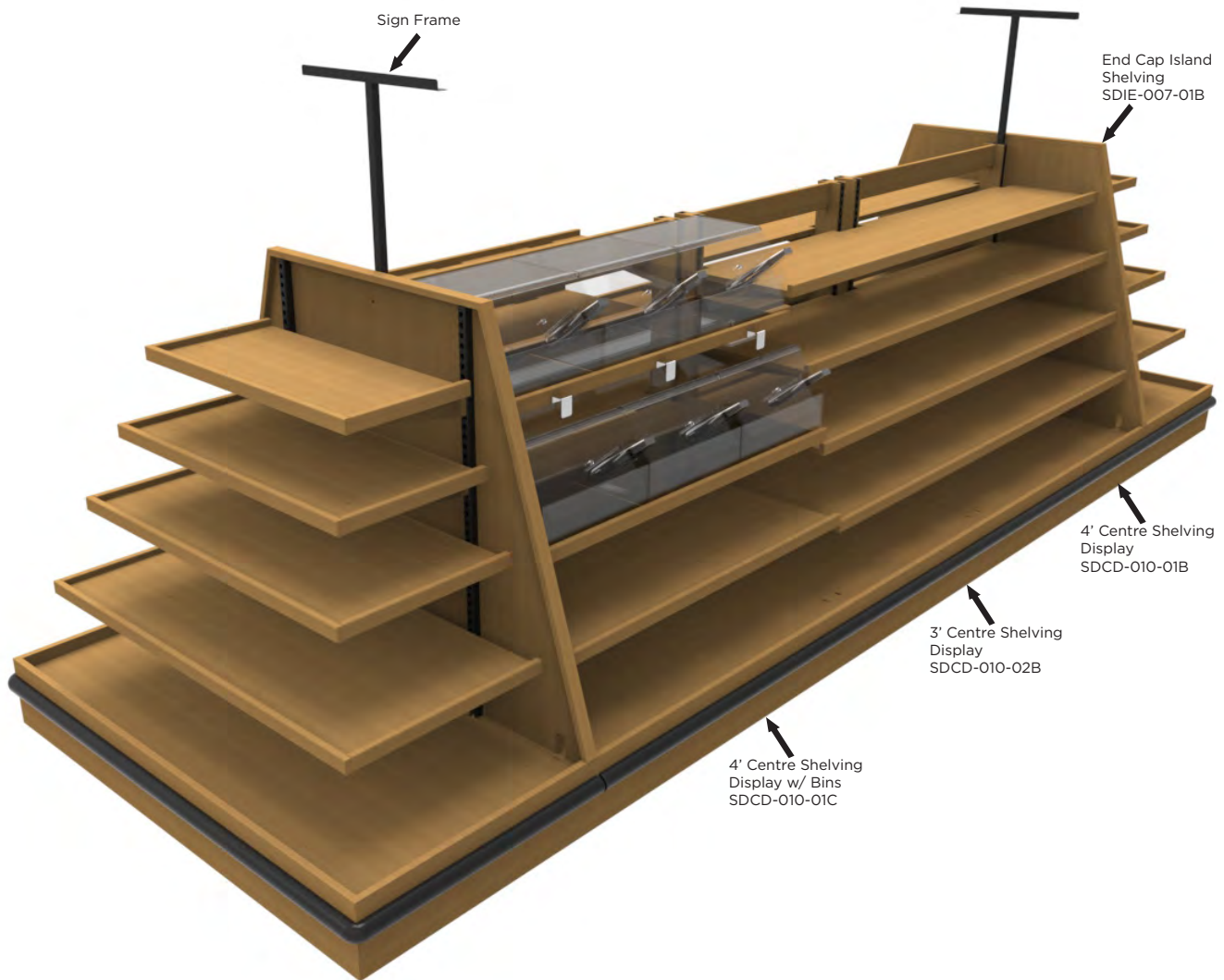

Applications

- The BFB Series is an island shelving display that allows for easy fastening together
- ABS bumper to help protect unit
- Both the 3' and 4' straight run allows for multiple combinations and the corner step allows for an 90° line up
- Custom corners available upon request

BFB SERIES BAKERY ISLAND SHELVING - END CAP



MODEL	DESCRIPTION	LENGTH	DEPTH	HEIGHT
SDIE-007-01B	Bakery Island Shelving - End Cap	60"	30"	52"

FEATURES:

- Birch/maple plywood & solid maple construction
- Levelers
- 2" McCue bumper
- Adjustable shelves - flat and 15° angle
- Shelf depths: 14"/17"/20"/ 23"

OPTIONS:

- ABS bumper (1 ½" or 2")
- McCue bumper (1")
- Corner Protectors
- Refer to Category C for Stain Finishes

Note: Information and specifications may change due to engineering improvements.

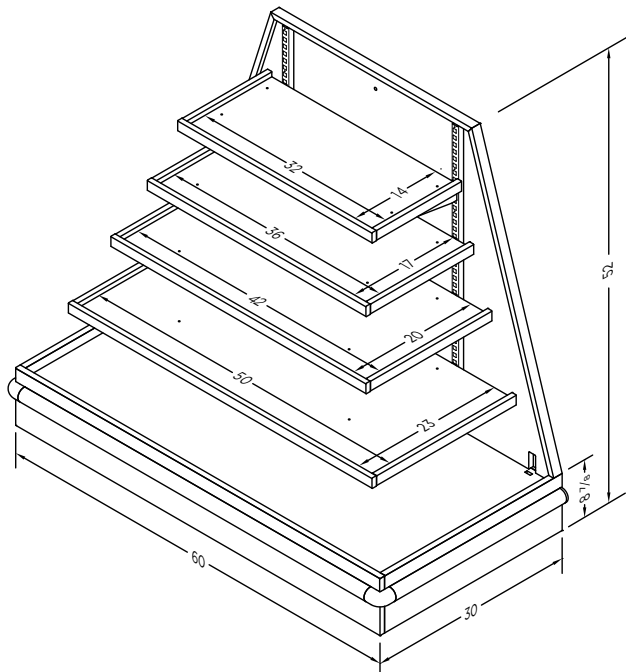

SDIE-007-01B

BFB SERIES ISLAND SHELVING - CENTRE

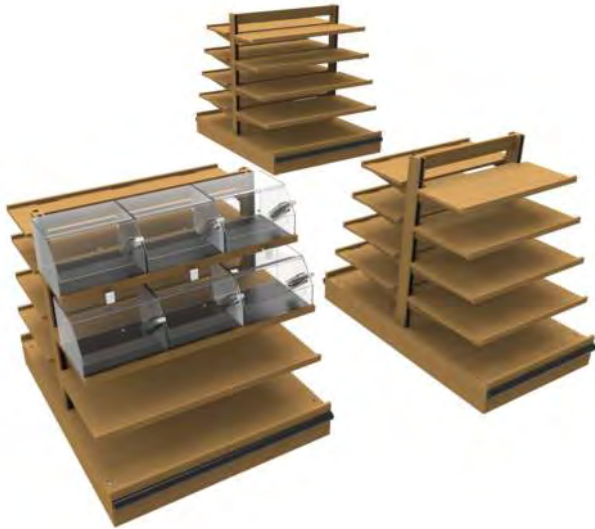

MODEL	DESCRIPTION	LENGTH	DEPTH	HEIGHT
SDCD-010-01B	Centre Island Shelving - 48"	47 ½"	60"	52"
SDCD-010-01C	Centre Island Shelving w/Bins - 48"	47 ½"	60"	52"
SDCD-010-02B	Centre Island Shelving - 36"	35 ½"	60"	52"

FEATURES:

- Birch/maple plywood & solid maple construction
- Levelers
- 2" McCue bumper
- Adjustable shelves - flat and 15° angle
- Shelf depths: 14"/17"/20"/ 23"

OPTIONS:

- ABS bumper (1 ½" or 2")
- McCue bumper (1")
- Corner Protectors
- See Page 47 for sign holder options
- Refer to Category C for Stain Finishes

Note: Information and specifications may change due to engineering improvements.

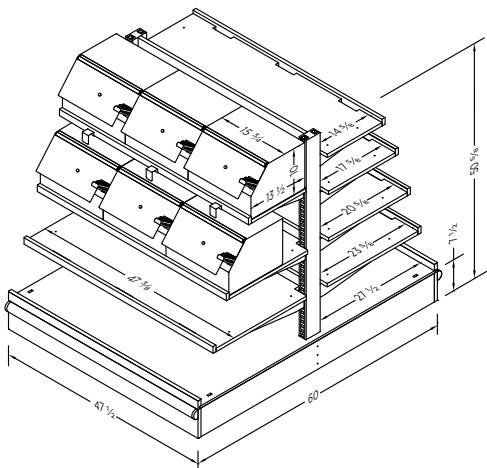

SDCD-010-01C

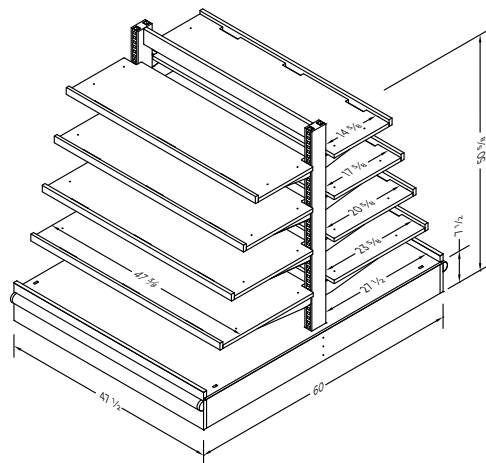

SDCD-010-01B

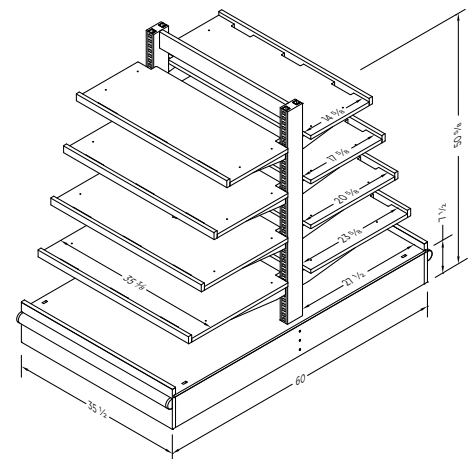

SDCD-010-02B

BSG SERIES MOBILE SHELVING DISPLAY

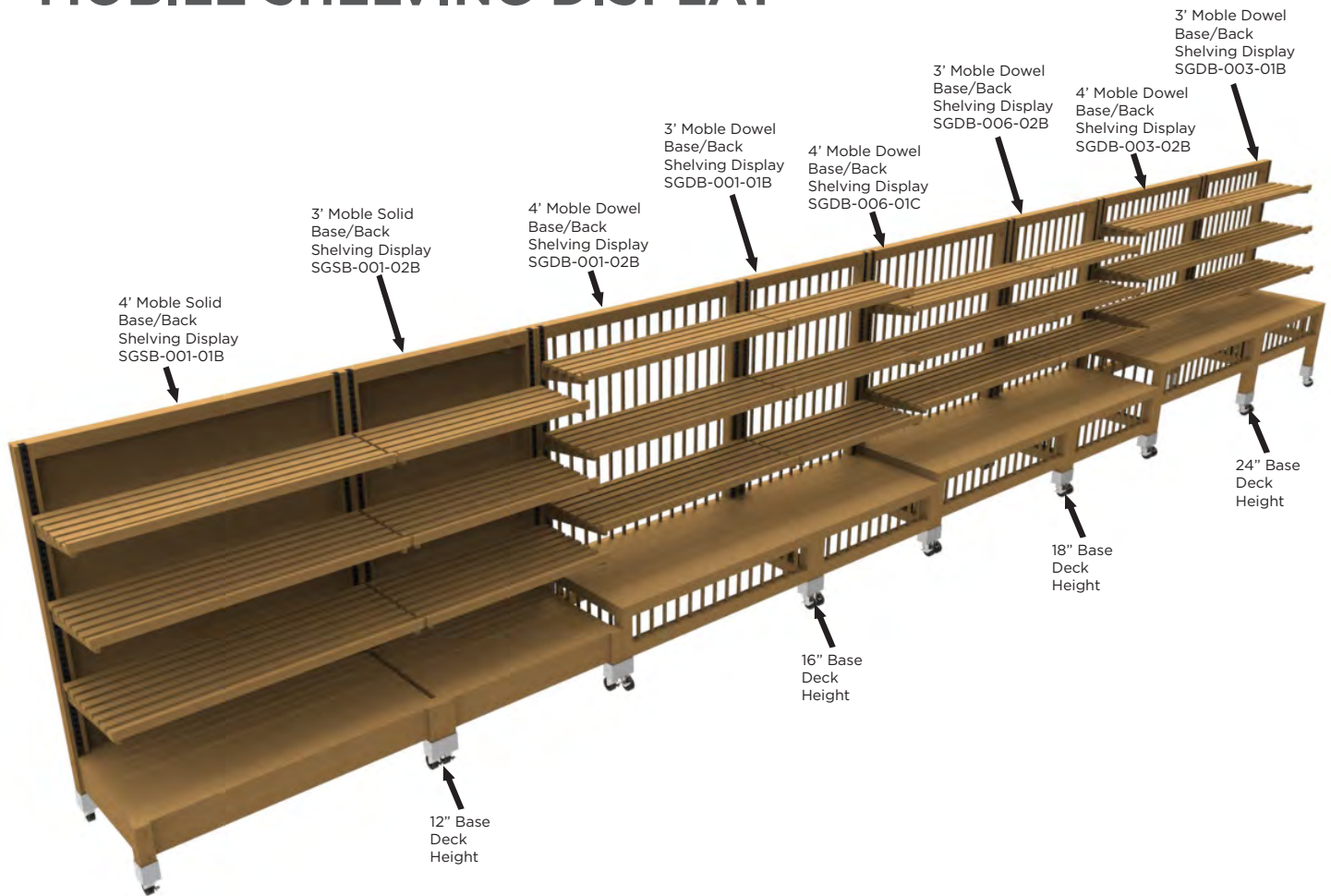

Applications

- The BSG Series is a versatile merchandising display that can be assembled in a straight run or in an island format
- Both the 3' and 4' units allow for multiple combinations\
- The 12" base deck height is the only unit with a solid base (no decorative dowel around base)
- Solid back units are also available in 16"/18"/24" base deck height with decorative dowel around base
- Units come with protective leg caps, and heavy duty locking casters
- There are various base deck heights available (12", 16", 18" & 24")
- ABS bumper and other accessories available upon request

BSG SERIES MOBILE SHELVING DISPLAY - SOLID BACK



MODEL	DESCRIPTION	LENGTH	DEPTH	HEIGHT
SGSB-001-01B	Mobile Display - 48" w/12" Base Height	48"	24"	60"
SGSB-001-02B	Mobile Display - 36" w/12" Base Height	36"	24"	60"

FEATURES:

- Birch/maple plywood & solid maple construction
- Heavy duty casters (2 locking)
- Protective leg caps
- Adjustable shelves - flat and 15° angle
- Shelf depths: 14"/16"/18"

OPTIONS:

- ABS bumper (1 ½" or 2")
- McCue bumper (1" or 2")
- 12" and 21" deep shelves available
- See Page 48 for sign holder options
- Refer to Category C for Stain Finishes

Note: Information and specifications may change due to engineering improvements.

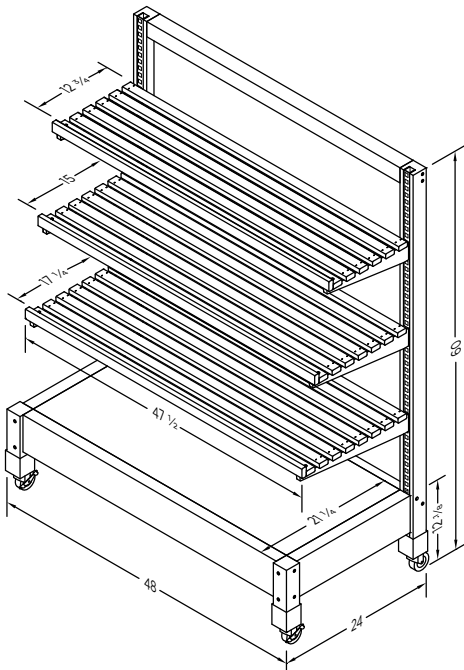

SGSB-001-01B

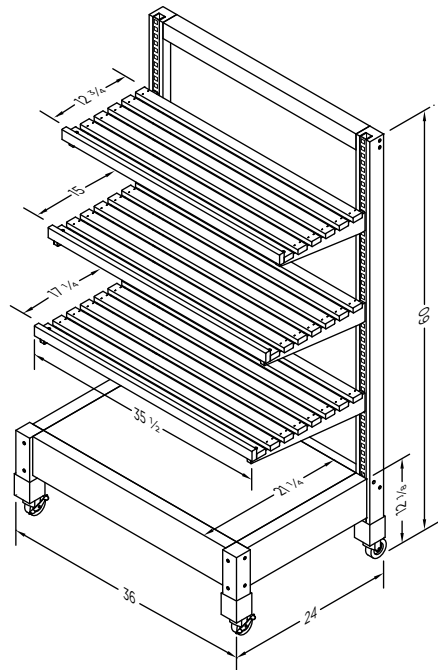

SGSB-001-02B

BSG SERIES MOBILE SHELVING DISPLAY - DOWEL BACK/ BASE



MODEL	DESCRIPTION	LENGTH	DEPTH	HEIGHT
SGDB-001-02B	Mobile Display - 48" w/16" Base Height	48"	24"	60"
SGDB-001-01B	Mobile Display - 36" w/16" Base Height	36"	24"	60"
SGDB-006-01C	Mobile Display - 48" w/18" Base Height	48"	24"	60"
SGDB-006-02B	Mobile Display - 36" w/18" Base Height	36"	24"	60"
SGDB-003-02B	Mobile Display - 48" w/21" Base Height	48"	24"	60"
SGDB-003-01B	Mobile Display - 36" w/21" Base Height	36"	24"	60"

FEATURES:

- Birch/maple plywood & solid maple construction
- Heavy duty casters (2 locking)
- Protective leg caps
- Adjustable shelves - flat and 15° angle
- Shelf depths: 12"/14"/16"

OPTIONS:

- ABS bumper (1 1/2" or 2")
- McCue bumper (1" or 2")
- 18" and 21" deep shelves available
- See Page 48 for sign holder options
- Refer to Category C for Stain Finishes

Note: Information and specifications may change due to engineering improvements.

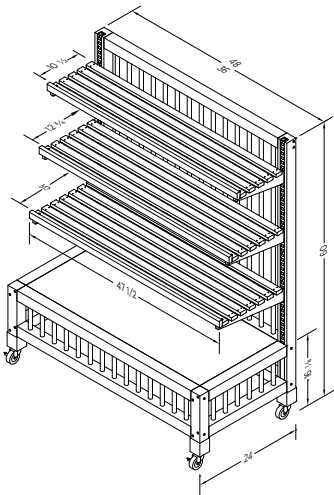

Mobile Display - 48" w/16" Base Height
SGDB-001-02B

Mobile Display - 36" w/16" Base Height
SGDB-001-01B

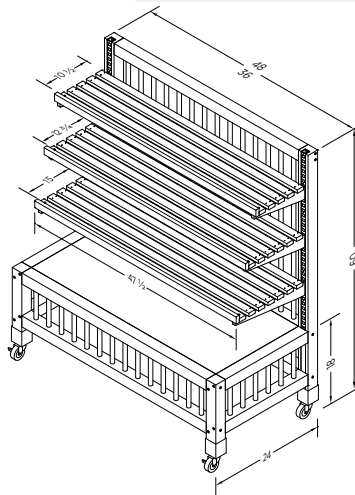

Mobile Display - 48" w/18" Base Height
SGDB-006-01C

Mobile Display - 36" w/18" Base Height
SGDB-006-02B

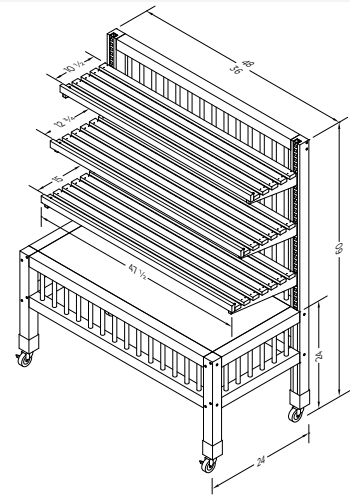

Mobile Display - 48" w/24" Base Height
SGDB-003-02B

Mobile Display - 36" w/24" Base Height
SGDB-003-01B

BCG SERIES MOBILE SHELVING DISPLAY

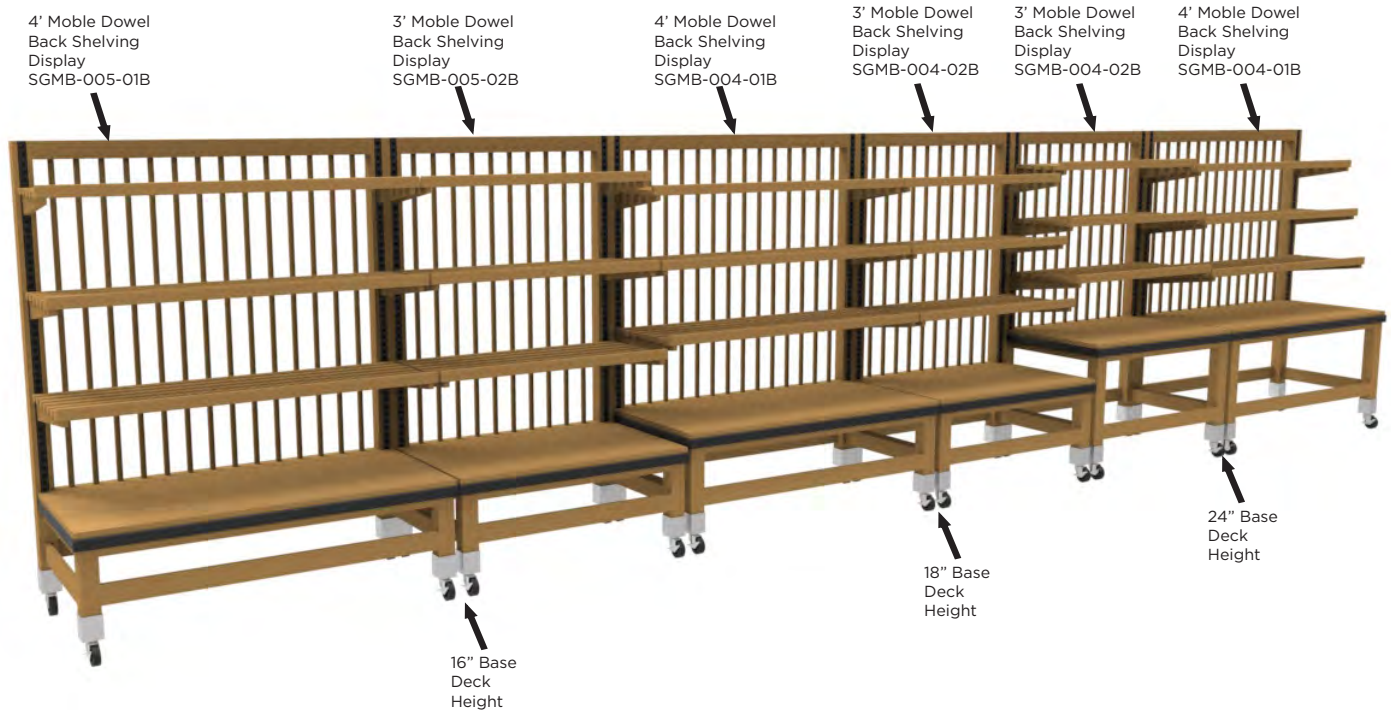

Applications

- The BCS Series is a versatile merchandising display that can be assembled in a straight run or in an island format
- Both the 3' and 4' units allow for multiple combinations
- Solid back units are also available in 16"/18"/24" base deck height instead of the decorative dowel back
- Units come with protective leg caps, and heavy duty locking casters
- There are various base deck heights available (Sol16", 18" & 24")
- ABS bumper and other accessories available upon request

BCG SERIES MOBILE SHELVING DISPLAY -DOWEL BACK



MODEL	DESCRIPTION	LENGTH	DEPTH	HEIGHT
SGMB-005-01B	Mobile Display - 48" w/16" Base Height	48"	24"	60"
SGMB-005-02B	Mobile Display - 36" w/16" Base Height	36"	24"	60"
SGMB-004-01B	Mobile Display - 48" w/18" Base Height	48"	24"	60"
SGMB-004-02B	Mobile Display - 36" w/18" Base Height	36"	24"	60"
SGMB-006-02B	Mobile Display - 48" w/21" Base Height	48"	24"	60"
SGMB-006-01B	Mobile Display - 36" w/21" Base Height	36"	24"	60"

FEATURES:

- Birch/maple plywood & solid maple construction
- Heavy duty casters (2 locking)
- Protective leg caps
- Adjustable shelves - flat and 15° angle
- Shelf depths: 12"/14"/16"

OPTIONS:

- ABS bumper (1 1/2" or 2")
- McCue bumper (1" or 2")
- 18" and 21" deep shelves available
- See Page 48 for sign holder options
- Refer to Category C for Stain Finishes

Note: Information and specifications may change due to engineering improvements.

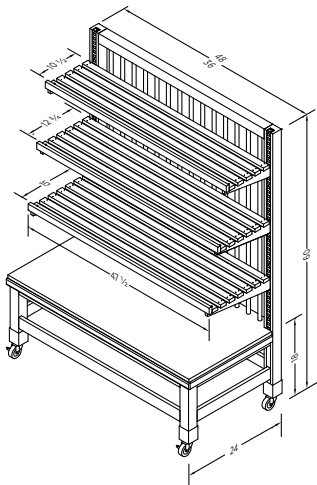

Mobile Display - 48" w/18" Base Height
SGMB-004-01B

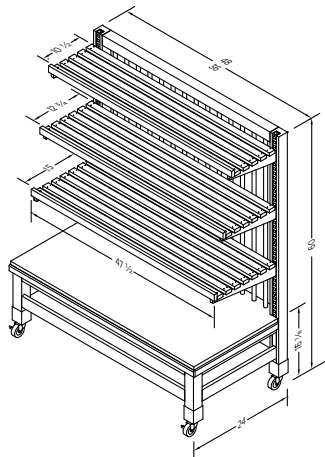

Mobile Display - 48" w/16" Base Height
SGMB-005-01B

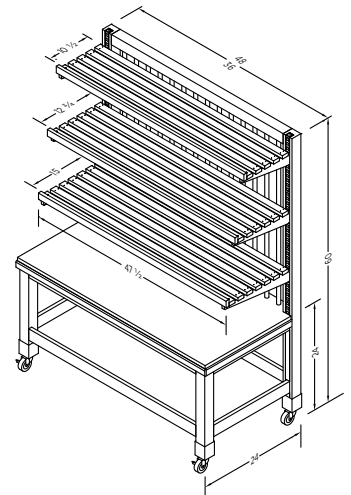

Mobile Display - 48" w/24" Base Height
SGMB-006-01B

Mobile Display - 36" w/18" Base Height
SGMB-004-02B

Mobile Display - 36" w/16" Base Height
SGMB-005-02B

Mobile Display - 36" w/24" Base Height
SGMB-006-02B

BNM SERIES BAKERY WALL SHELVING

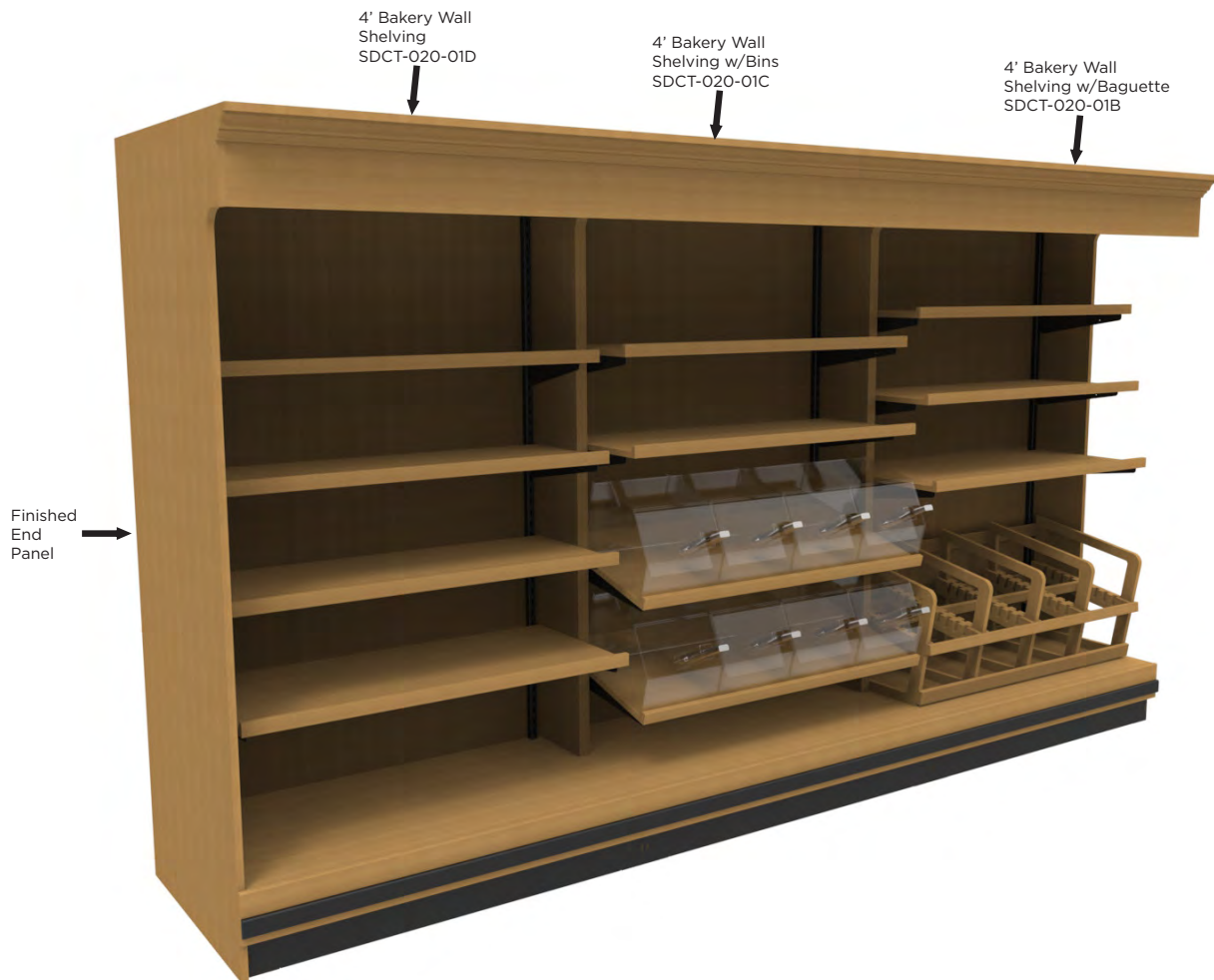

Applications

- The BNM Series is a merchandising display with removable kicks to allow units to be leveled and fastened together as well as has a bumper to help protect the unit
- Shelves, baguette rack and bins are interchangeable between units
- Levelers and LED lighting in canopy
- PTM and finished end gables available upon request

BNM SERIES BAKERY WALL SHELVING



MODEL	DESCRIPTION	LENGTH	DEPTH	HEIGHT
SDCT-020-01B	Bakery Wall Shelving w/ Baguette	48"	37 3/4"	84"
SDCT-020-01C	Bakery Wall Shelving w/ Bins	48"	37 3/4"	84"
SDCT-020-01D	Bakery Wall Shelving	48"	37 3/4"	84"

FEATURES:

- Birch/maple plywood & solid maple construction
- Levelers
- 2" ABS bumper
- Adjustable shelves - flat and 15° angle
- LED lighting in canopy
- Removable kick

OPTIONS:

- ABS bumper (1 1/2" or 2")
- McCue bumper (1" or 2")
- 14"/ 16"/18" and 21" deep shelves available
- PTM and end Gables
- Refer to Category C for Stain Finishes

Note: Information and specifications may change due to engineering improvements.

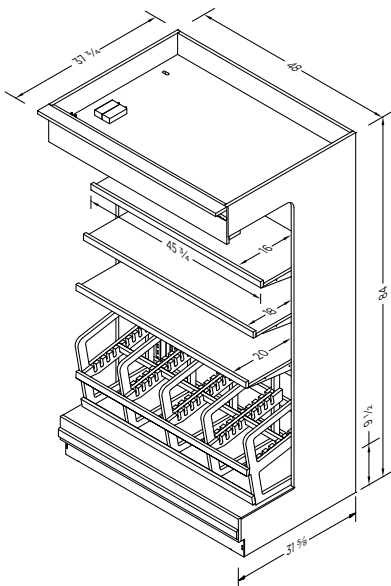

SDCT-020-01B

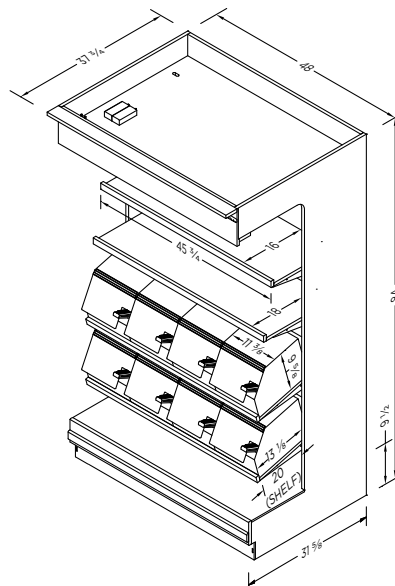

SDCT-020-01C

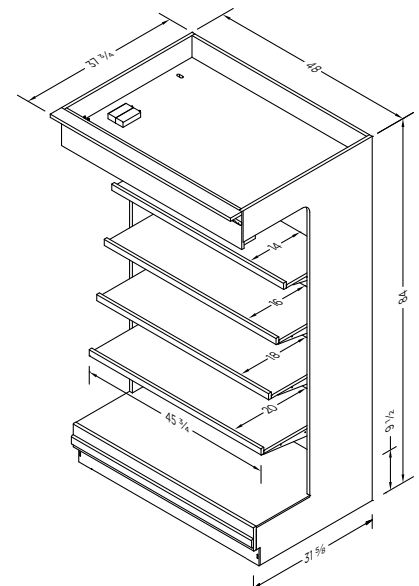

SDCT-020-01B

BCW SERIES WALL SHELVING DISPLAY

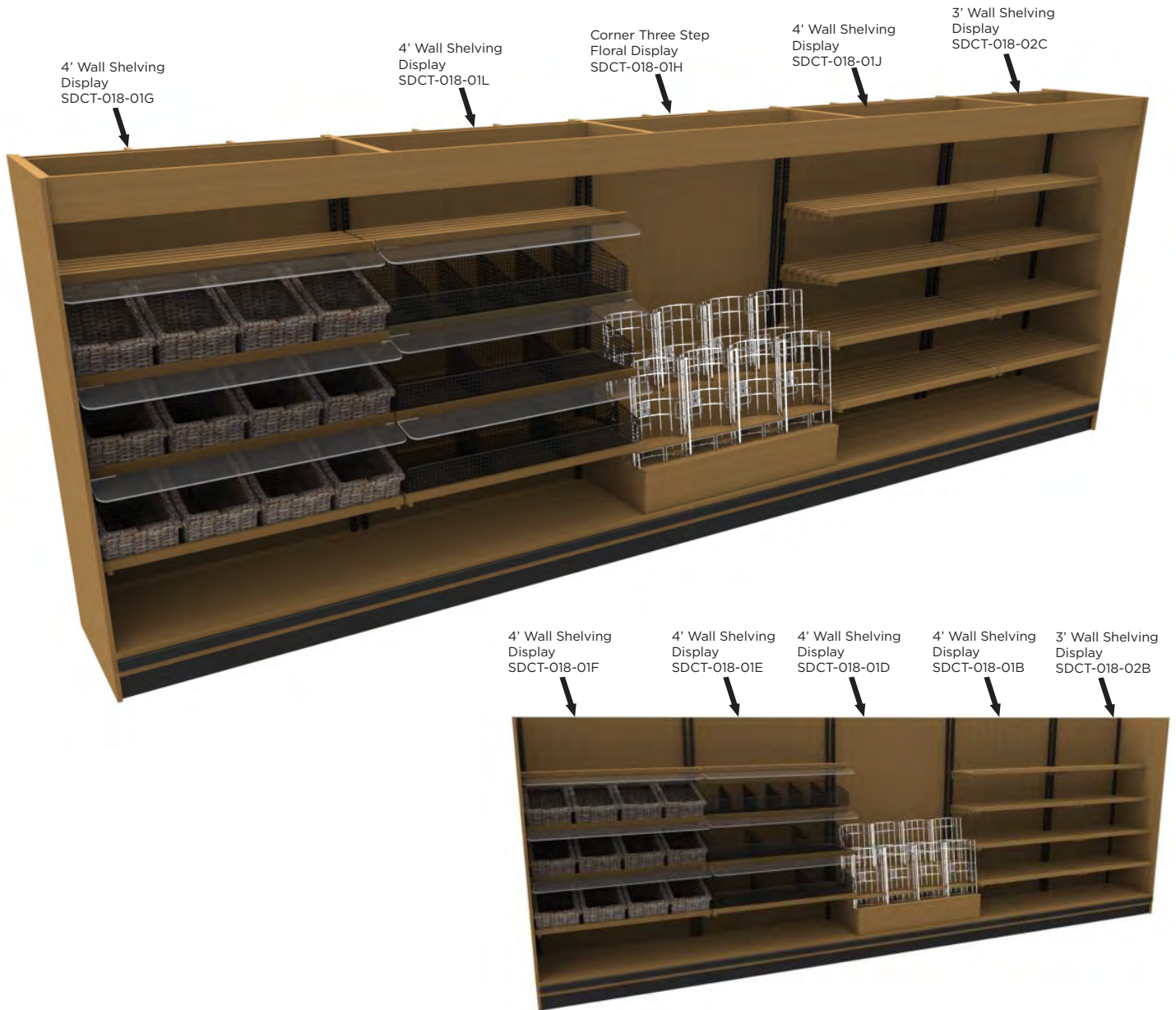

Applications

- The BCW Series is a versatile merchandising display that allows for easy customization with the numerous accessories available
- Both the 3' and 4' straight run allows for multiple combinations and
- Separate end panels allow units to be arranged on site then attached after displays are in place to allow layout to be adjusted if required
- ABS bumper, waterfall shelves and either with or without canopy

BCW SERIES BAKERY WALL SHELVING



MODEL	DESCRIPTION	LENGTH	DEPTH	HEIGHT
SDCT-018-01B	Wall Shelving -4'	48"	27"	78"
SDCT-018-02B	Wall Shelving -3'	36"	27"	78"
SDCT-018-01J	Wall Shelving w/ Canopy -4'	48"	27"	78"
SDCT-018-02C	Wall Shelving w/ Canopy -3'	36"	27"	78"

FEATURES:

- Birch/maple plywood & solid maple construction
- 2" ABS bumper
- Adjustable shelves - flat and 15° angle
- Shelf depths: 14"/16"/18"/21"

OPTIONS:

- ABS bumper (1 1/2")
- McCue bumper (1" or 2")
- 12" deep shelf available
- Refer to Category C for Stain Finishes

Note: Information and specifications may change due to engineering improvements.

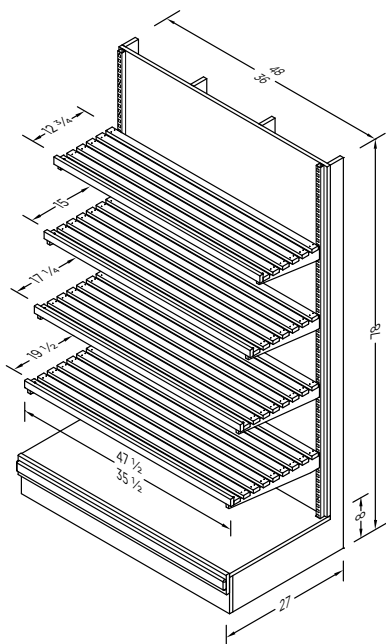

Wall Shelving Display - 48"
SDCT-018-01B

Wall Shelving Display - 36"
SDCT-018-02B

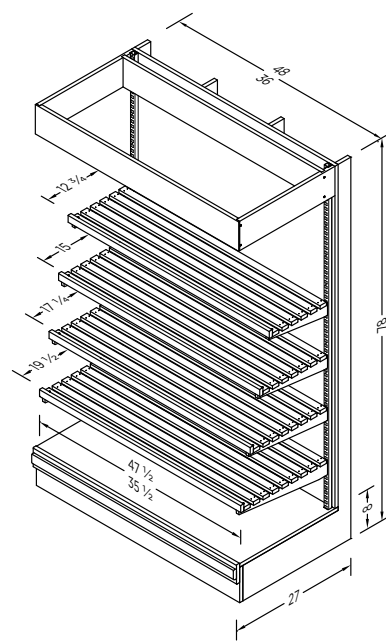

Wall Shelving Display - 48"
SDCT-018-01J

Wall Shelving Display - 36"
SDCT-018-02C

BCW SERIES

BAKERY WALL SHELVING ACCESSORIES- 3' & 4'



SDCT-018-01J
shown with Maple
Slatted Shelves

SDCT-018-01C
shown with Birch/
Maple Plywood Shelves

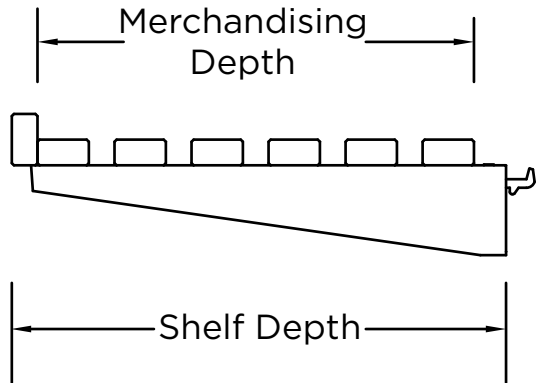

MODEL	DESCRIPTION	LENGTH	MERCH. DEPTH
Maple Slatted Shelves			
SHMS-AA-12.00-35.50	12" x 3'	35 ½"	10 ½"
SHMS-AA-14.00-35.50	14" x 3'		12 ¾"
SHMS-AA-16.00-35.50	16" x 3'		15"
SHMS-AA-18.00-35.50	18" x 3'		17 ¼"
SHMS-AA-21.00-35.50	21" x 3'		19 ½"
SHMS-AA-12.00-47.50	12" x 4'	47 ½"	10 ½"
SHMS-AA-14.00-47.50	14" x 4'		12 ¾"
SHMS-AA-16.00-47.50	16" x 4'		15"
SHMS-AA-18.00-47.50	18" x 4'		17 ¼"
SHMS-AA-21.00-47.50	21" x 4'		19 ½"
Birch/Maple Plywood Shelves			
SHMP-AA-12.00-35.50	12" x 3'	35 ½"	10 ½"
SHMP-AA-14.00-35.50	14" x 3'		12 ¾"
SHMP-AA-16.00-35.50	16" x 3'		15"
SHMP-AA-18.00-35.50	18" x 3'		17 ¼"
SHMP-AA-21.00-35.50	21" x 3'		19 ½"
SHMP-AA-12.00-47.50	12" x 4'	47 ½"	10 ½"
SHMP-AA-14.00-47.50	14" x 4'		12 ¾"
SHMP-AA-16.00-47.50	16" x 4'		15"
SHMP-AA-18.00-47.50	18" x 4'		17 ¼"
SHMP-AA-21.00-47.50	21" x 4'		19 ½"

OPTIONS:

- Refer to Category C for Stain Finishes

Note: Information and specifications may change due to engineering improvements.



Maple Slatted
Shelves

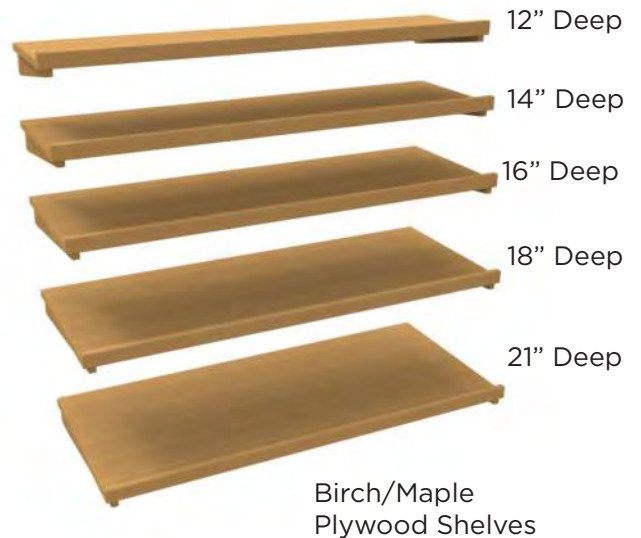

Birch/Maple
Plywood Shelves

BAKERY WALL SHELVING ACCESSORIES CONT'D



SCSG-001-01A (4')
SCSG-001-02A (3')

MODEL	DESCRIPTION	LENGTH	DEPTH	HEIGHT
SCSG-001-01A	Bent Acrylic Sneezeguard - 48"	47 1/2"	5 7/8"	-
SCSG-001-02A	Bent Acrylic Sneezeguard - 36"	35 1/4"	5 7/8"	-
ACWB-002-01A	Metal Basket - Lg	15 1/8"	14 1/8"	5 1/8" Lip
ACWB-003-01A	Metal Basket - Sm	7 1/2"	14 1/8"	5 1/8" Lip
4/115	Wicker Basket	12"	17 1/2"	5 1/8" Lip

Note: Information and specifications may change due to engineering improvements.

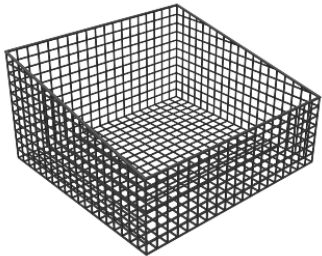

ACWB-002-01A



ACWB-003-01A



4/115

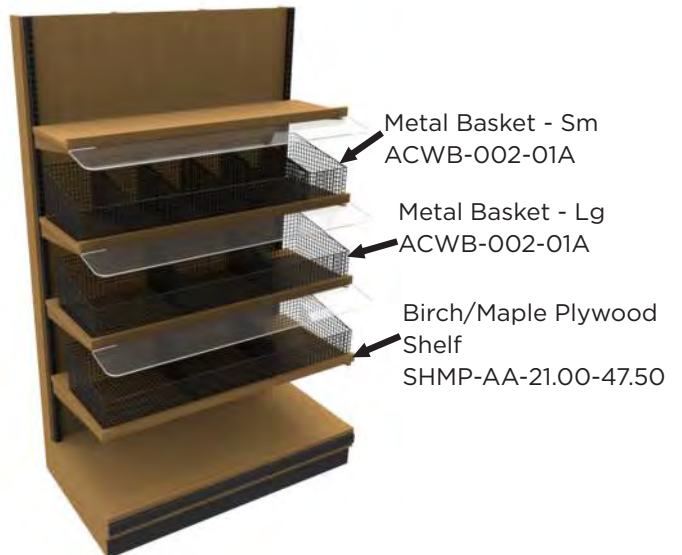
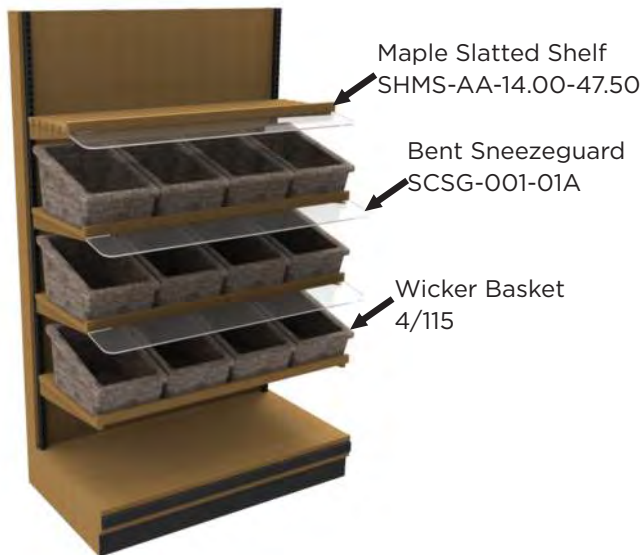

BAKERY WALL SHELVING ACCESSORIES CONT'D



ACSN-014-01B (4')
ACSN-014-02B (3')

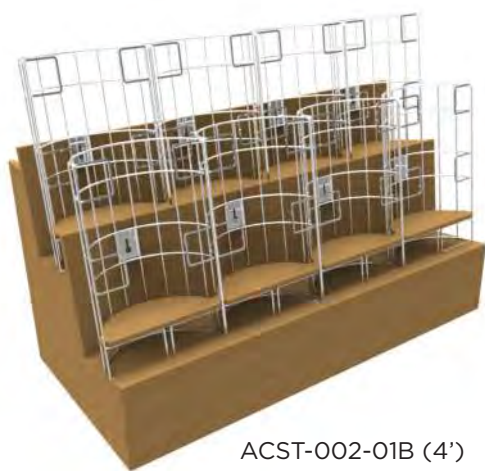

ACST-002-01B (4')
ACST-002-02B (3')

MODEL	DESCRIPTION	LENGTH	DEPTH	HEIGHT
ACSN-014-01B	Clip on Canopy-48"	48"	24"	60"
ACSN-014-02B	Clip on Canopy-36"	36"	24"	60"
ACST-002-01B	Baguette Riser Step - 48"	48"	22 ½"	34 ½"
ACST-002-02B	Baguette Riser Step - 36"	36"	22 ½"	34 ½"

FEATURES:

- Birch/maple plywood construction
- ACST-002-01B & ACST-002-02B
Metal Baguette baskets w/ false floor

OPTIONS:

- Refer to Category C for Stain Finishes

Note: Information and specifications may change due to engineering improvements.

