



FLORAL

COLLECTION

 **Cayuga** DISPLAYS



DEPARTMENT: FLORAL

The floral department is a beautiful opportunity to enhance the fresh, vital impression of your overall store. We help you make the most of your stock, in its presentation and preservation!

The highly fluctuating nature of the floral department inventory means display units need to be versatile. We offer a number of mobile-friendly shelves, tables and cases to move easily out of the way when not needed and to blend seamlessly with the fixed components.

"I have worked with various fixture and millwork suppliers and I must say that Cayuga has provided me with the best product and service of them all."

Sharon Young, McGinnis Sisters
Special Food Stores.
Pittsburgh, PA

FSY SERIES

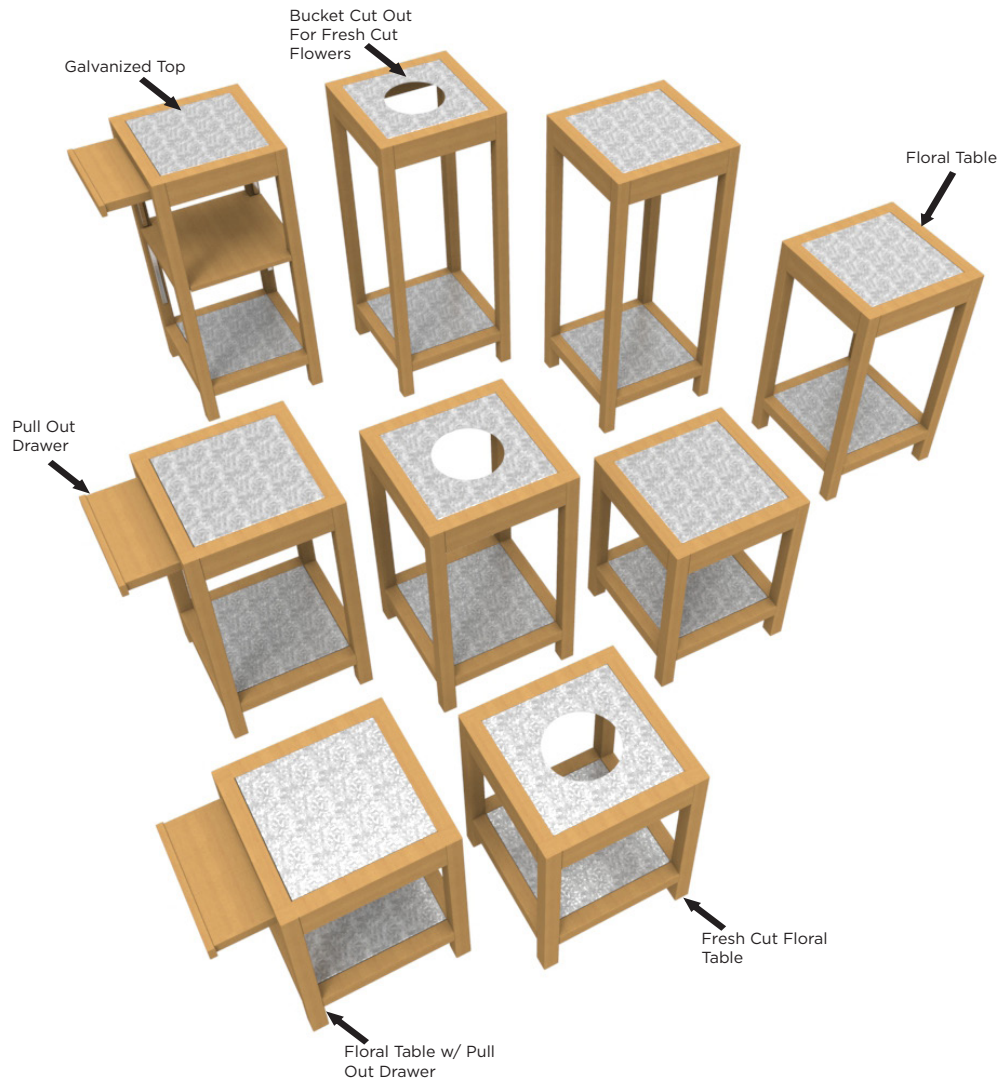

Applications

- The FSY Series of tables are designed to be easily installed into any configuration setup
- Both upper and lower table tops are made of galvanized steel
- Tack glides
- Fresh cut tables allow merchandising of both fresh and potted flowers due to the unique design that allows the table to be converted from solid top to top with bucket cut out (galvanized top when not in use easily stores onto of lower shelf)

FSY SERIES FLORAL TABLE w/ PULL OUT DRAWER



MODEL	DESCRIPTION	LENGTH	LENGTH	HEIGHT
TBFL-001-01B	Floral Table w/ Pull Out Drawer - Short	18"	18"	24 1/4"
TBFL-002-01B	Floral Table w/ Pull Out Drawer - Medium	18"	18"	32 1/4"
TBFL-003-01B	Floral Table w/ Pull Out Drawer - Tall	18"	18"	40 1/4"

FEATURES:

- Birch/maple plywood & solid maple construct with galvanized pan inserts
- Tack glides
- Pull out drawer

OPTIONS:

- Stain Finishes - see page 27

Note: Information and specifications may change due to engineering improvements.

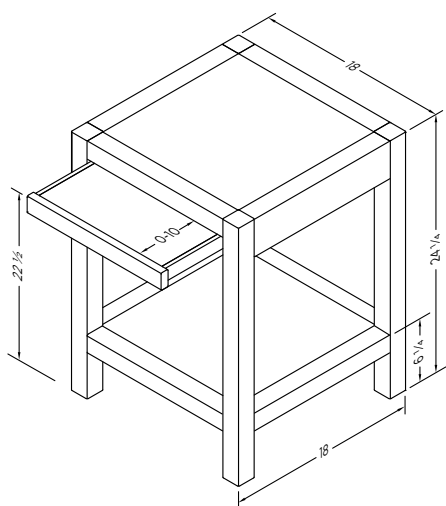

TBFL-001-01B

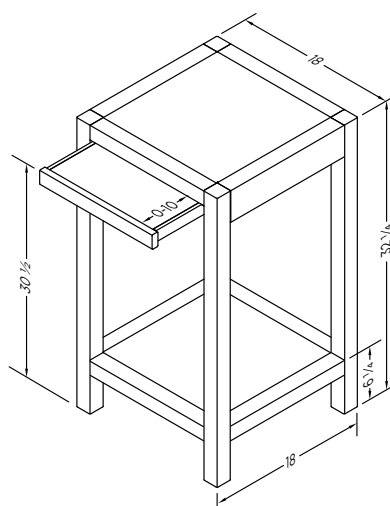

TBFL-002-01B

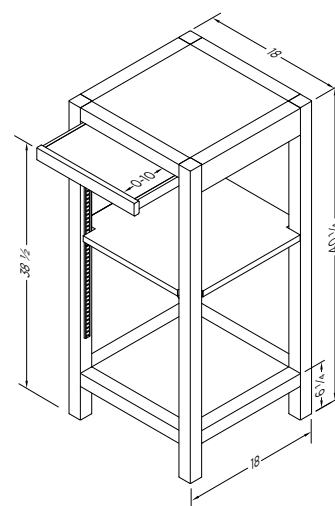

TBFL-003-01B

FSY SERIES FRESH CUT FLORAL TABLES

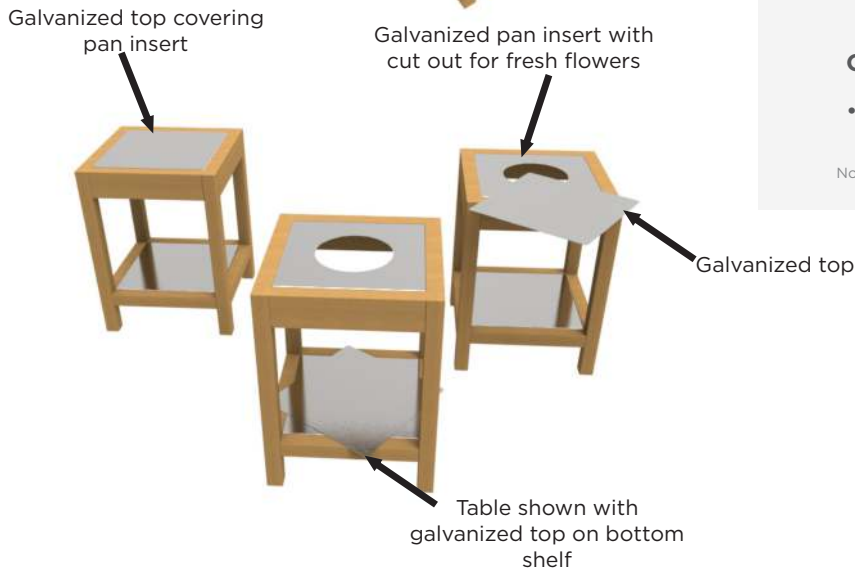

MODEL	DESCRIPTION	LENGTH	DEPTH	HEIGHT
TBFL-004-01B	Fresh Cut Floral Table - Short	18"	18"	24 1/4"
TBFL-005-01B	Fresh Cut Floral Table - Medium	18"	18"	32 1/4"
TBFL-006-01B	Fresh Cut Floral Table - Tall	18"	18"	42 1/4"

FEATURES:

- Birch/maple plywood & solid maple construct with galvanized pan inserts - one pan solid & one pan with cut out for fresh cut flowers
- Removable galvanized top used to cover hole for fresh cut flowers
- Tack glides

OPTIONS:

- Stain Finishes - see page 27

Note: Information and specifications may change due to engineering improvements.

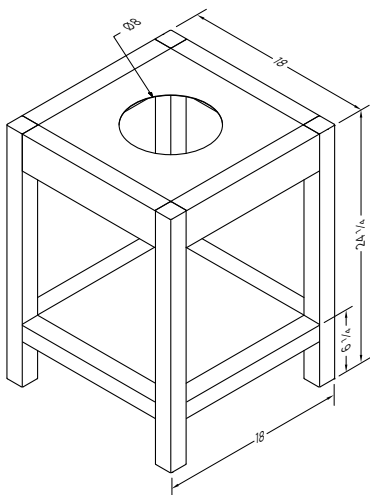

TBFL-004-01B

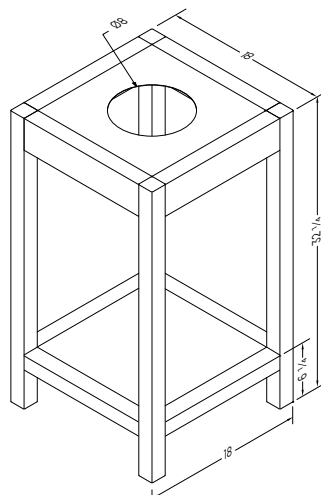

TBFL-005-01B

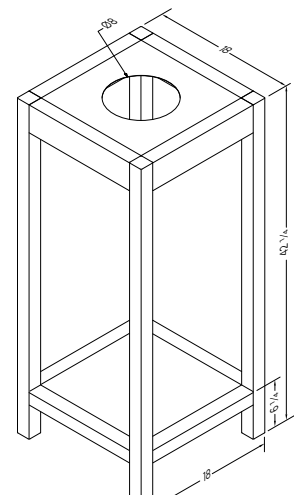

TBFL-006-01B

FSY SERIES FLORAL TABLES



MODEL	DESCRIPTION	LENGTH	DEPTH	HEIGHT
TBFL-004-01C	Floral Table - Short	18"	18"	24 1/4"
TBFL-005-01C	Floral Table - Medium	18"	18"	32 1/4"
TBFL-006-01C	Floral Table - Tall	18"	18"	42 1/4"

FEATURES:

- Birch/maple plywood & solid maple construct with galvanized pan inserts
- Tack glides

OPTIONS:

- Stain Finishes - see page 27

Note: Information and specifications may change due to engineering improvements.

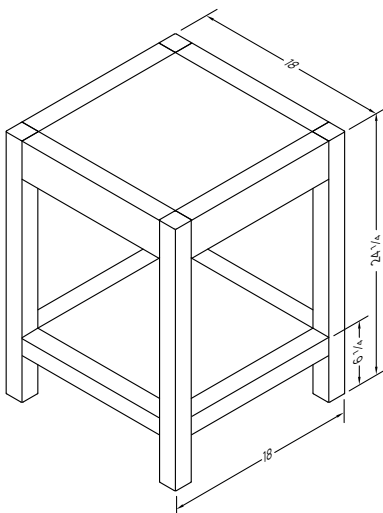

TBFL-004-01C

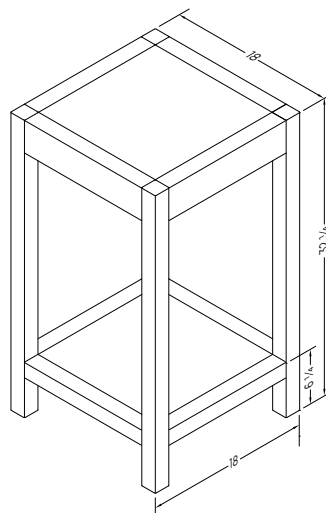

TBFL-005-01C

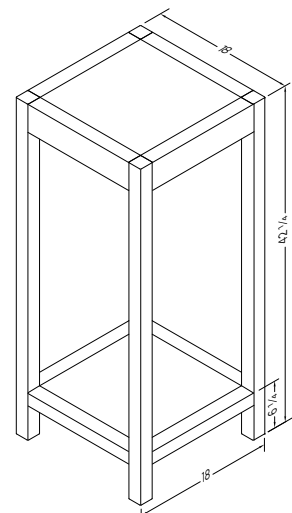

TBFL-006-01C

F2S SERIES

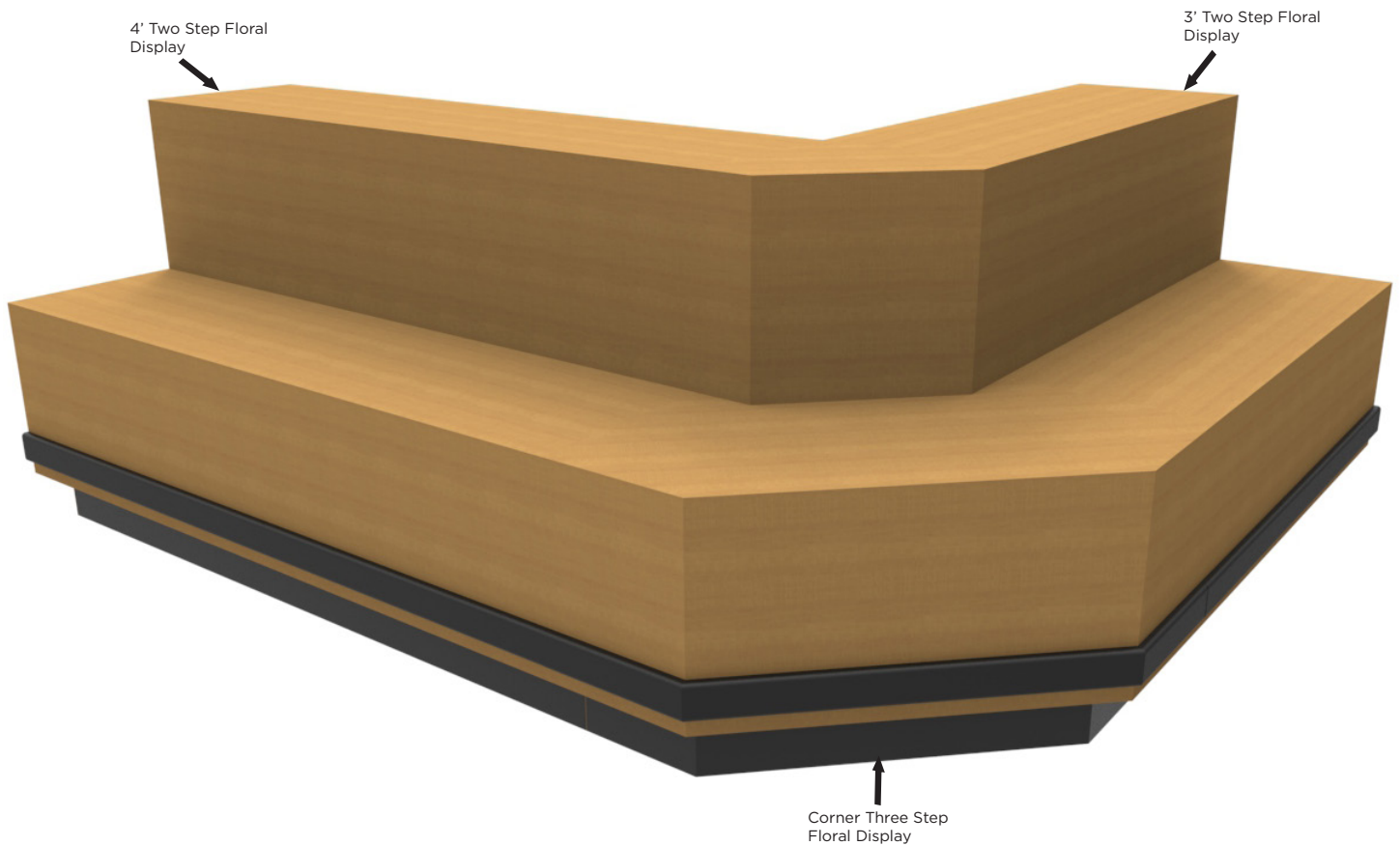

Applications

- The F2S Series is a two step floral merchandising display that is laminated to allow for easy cleaning as well as bumper to help protect unit
- Both the 3' and 4' straight run allows for mutiple combinations and the corner step allows for an 90° line up
- Custom corners available upon request

F2S SERIES FLORAL STEPS - 2 STEP



MODEL	DESCRIPTION	LENGTH	DEPTH	HEIGHT
ST2S-001-01B	Floral Step - 48"	48"	24"	28"
ST2S-001-02B	Floral Step - 36"	36"	24"	28"

FEATURES:

- Birch/maple plywood & laminate construct
- ABS bumper

OPTIONS:

- Finishes - see page 27

Note: Information and specifications may change due to engineering improvements.

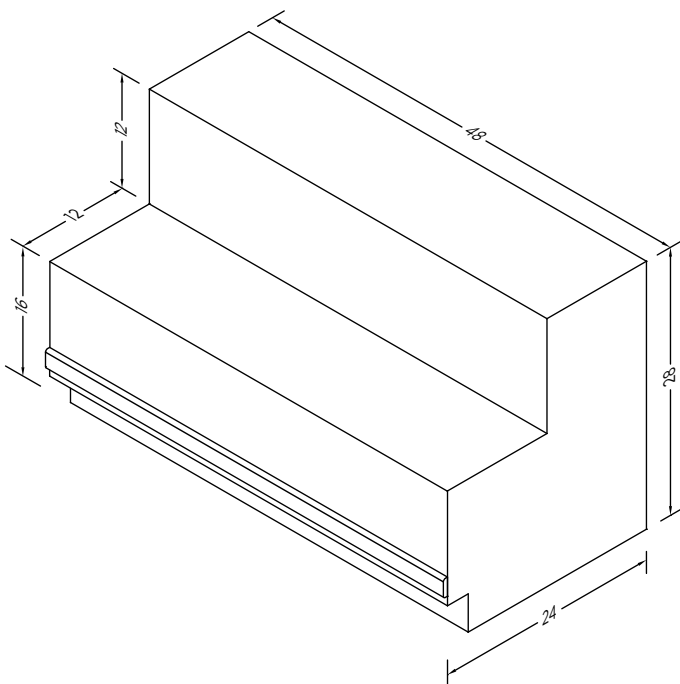

ST2S-001-01B

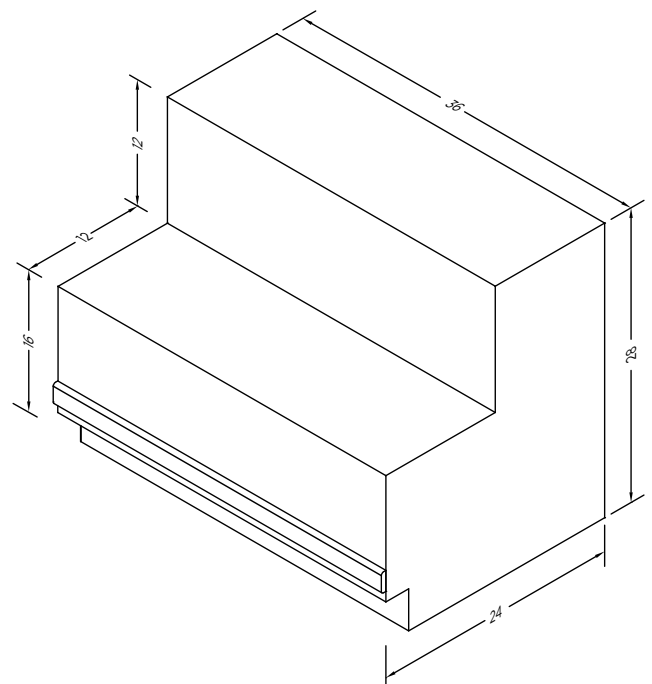

ST2S-001-02B

F2S SERIES CORNER FLORAL STEP - 2 STEP



MODEL	DESCRIPTION	LENGTH	DEPTH	HEIGHT
ST2S-001-01B	Corner Floral Step - 42"	24"	24"	28"

FEATURES:

- Birch/maple plywood & laminate construct
- ABS bumper

OPTIONS:

- Finishes - see page 27

Note: Information and specifications may change due to engineering improvements.

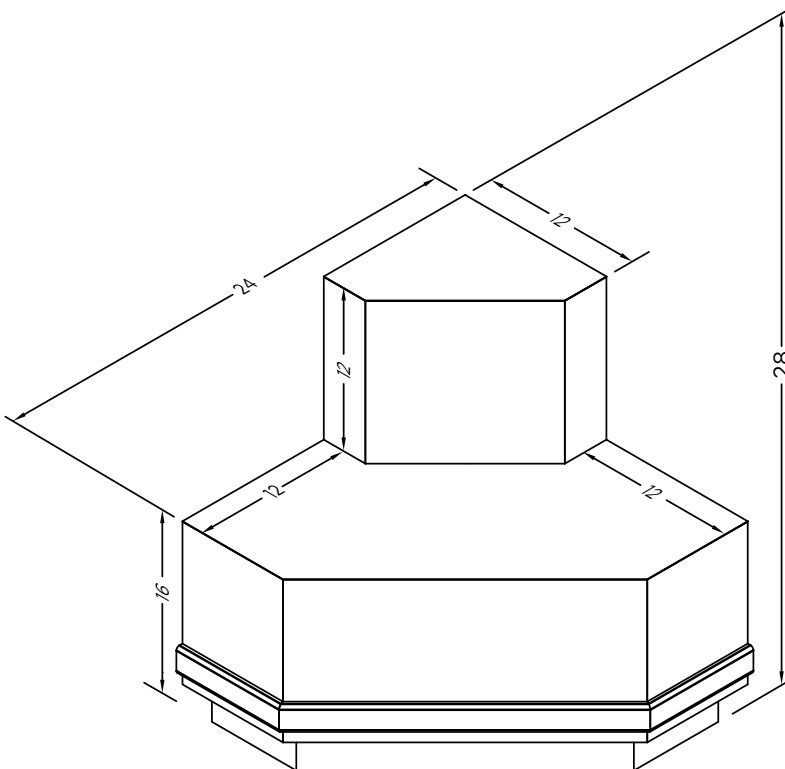

ST2S-004-01B

F3S SERIES

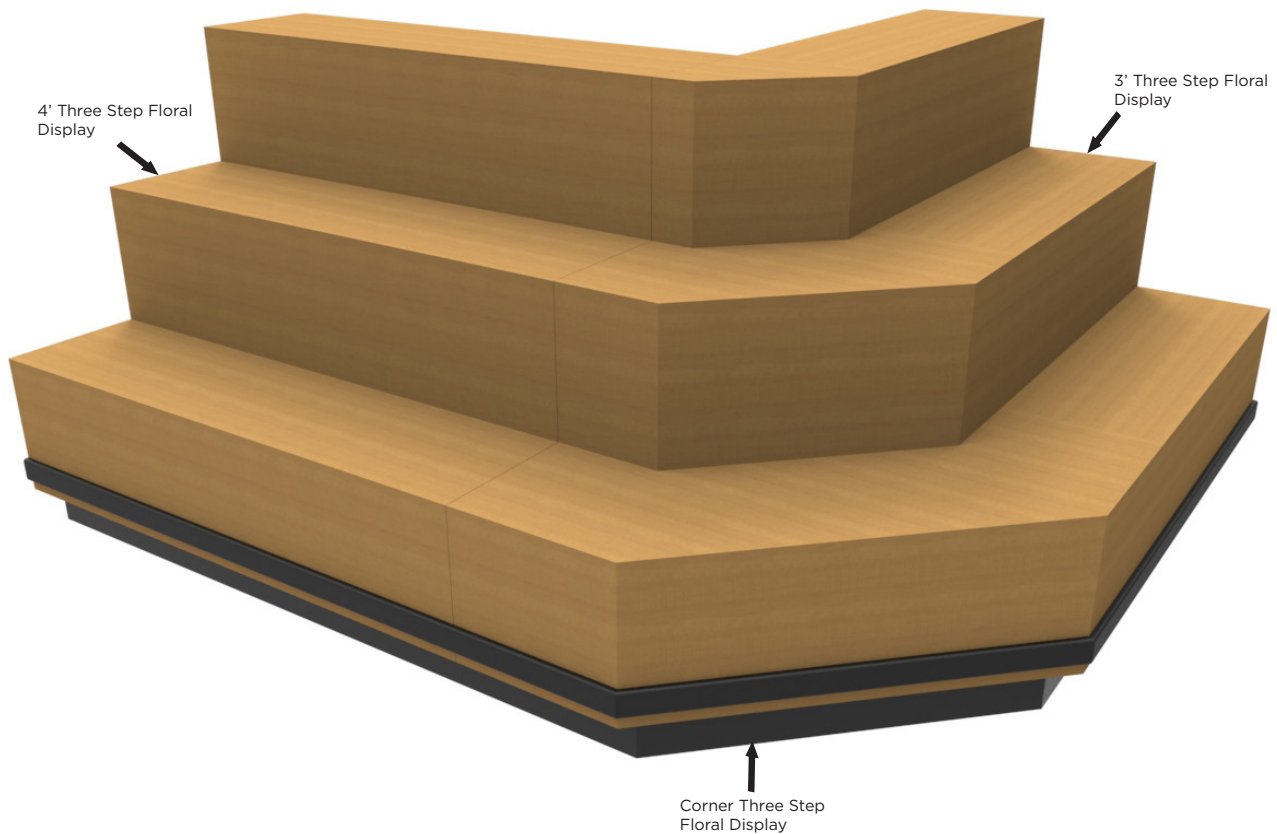

Applications

- The F3S Series is a three step floral merchandising display that is laminated to allow for easy cleaning as well as bumper to help protect unit
- Both the 3' and 4' straight run allows for multiple combinations and the corner step allows for a 90° line up
- Custom corners available upon request

F3S SERIES FLORAL STEPS - 3 STEP



MODEL	DESCRIPTION	LENGTH	DEPTH	HEIGHT
ST3S-001-01B	Floral Step - 48"	48"	36"	40"
ST3S-001-02B	Floral Step - 36"	36"	36"	40"

FEATURES:

- Birch/maple plywood & laminate construct
- ABS bumper

OPTIONS:

- Finishes - see page 27

Note: Information and specifications may change due to engineering improvements.

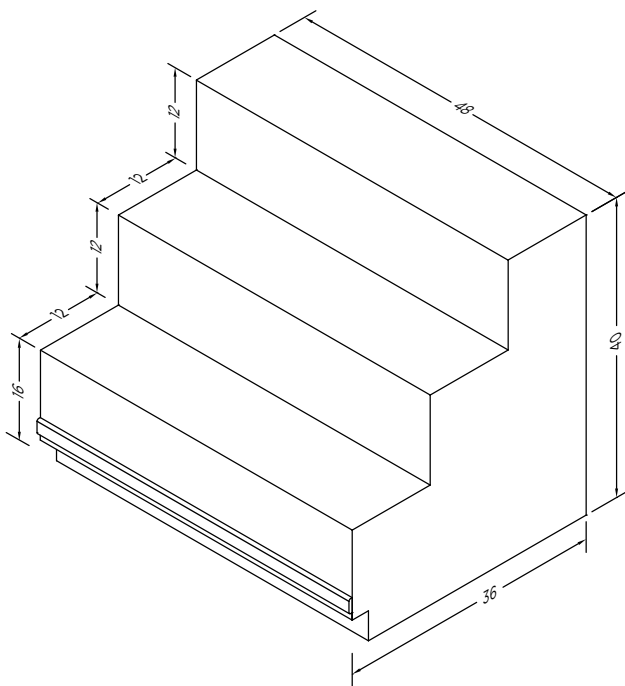

ST3S-001-01B

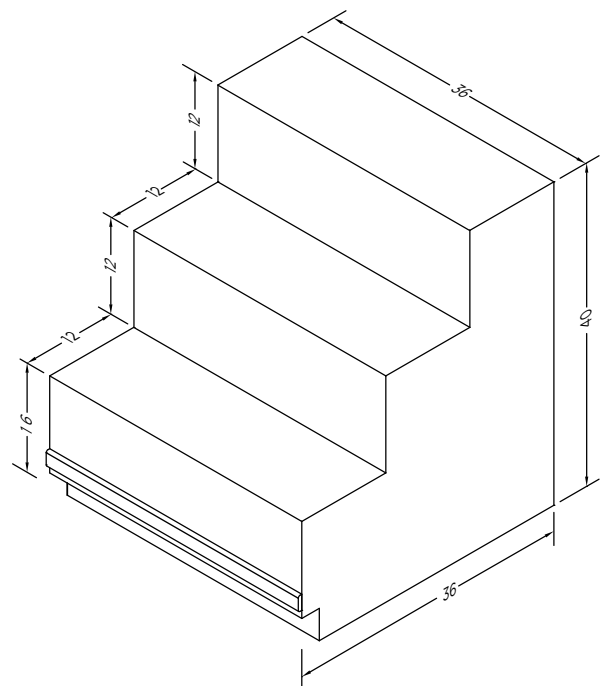

ST3S-001-02B

F3S SERIES CORNER FLORAL STEP - 3 STEP

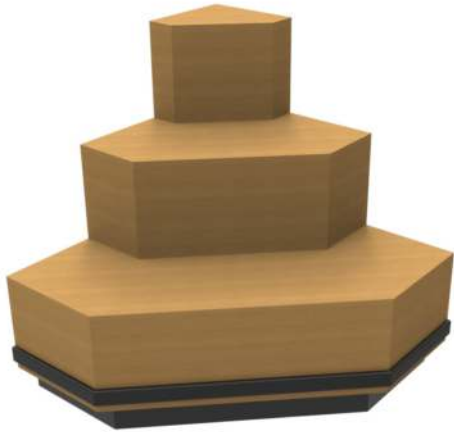

MODEL	DESCRIPTION	LENGTH	DEPTH	HEIGHT
ST3S-004-01B	Corner Floral Step	36"	36"	40"

FEATURES:

- Birch/maple plywood & laminate construct
- ABS bumper

OPTIONS:

- Finishes - see page 27

Note: Information and specifications may change due to engineering improvements.

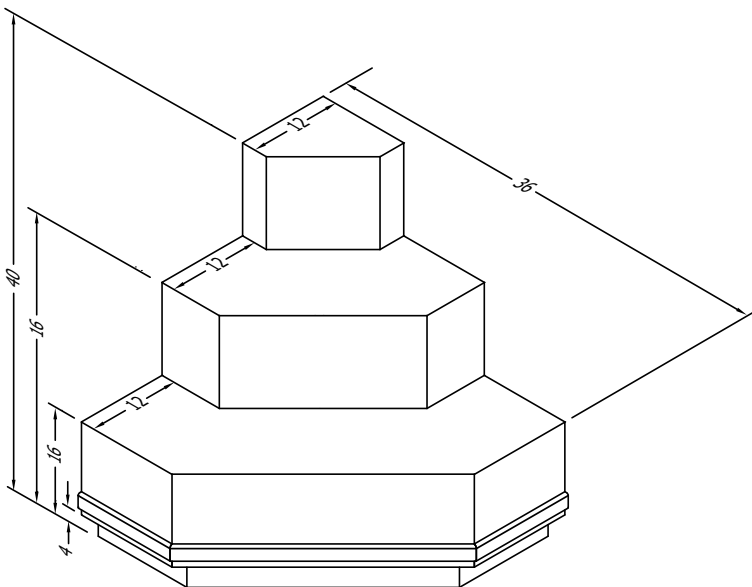

ST3S-004-01B

FIXTURES

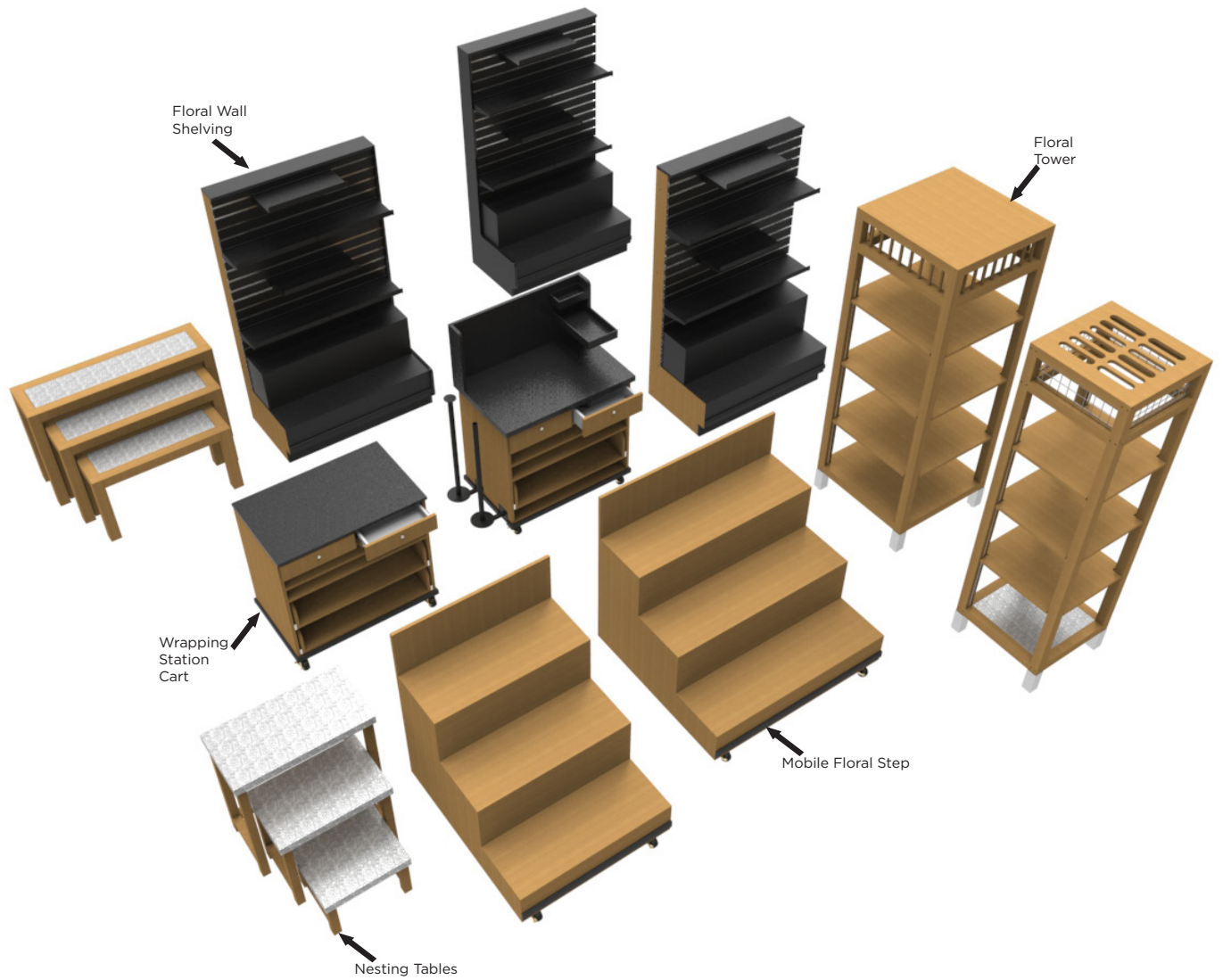

MOBILE FLORAL STEPS - 3 STEP



MODEL	DESCRIPTION	LENGTH	DEPTH	HEIGHT
ST3S-002-01B	Mobile Floral Step - 48"	48"	42 3/4"	48"
ST3S-002-02B	Mobile Floral Step - 36"	36"	42 3/4"	38"

FEATURES:

- Birch/maple plywood & laminate construct
- Heavy duty locking casters
- ABS bumper

OPTIONS:

- Finishes - see page 27

Note: Information and specifications may change due to engineering improvements.

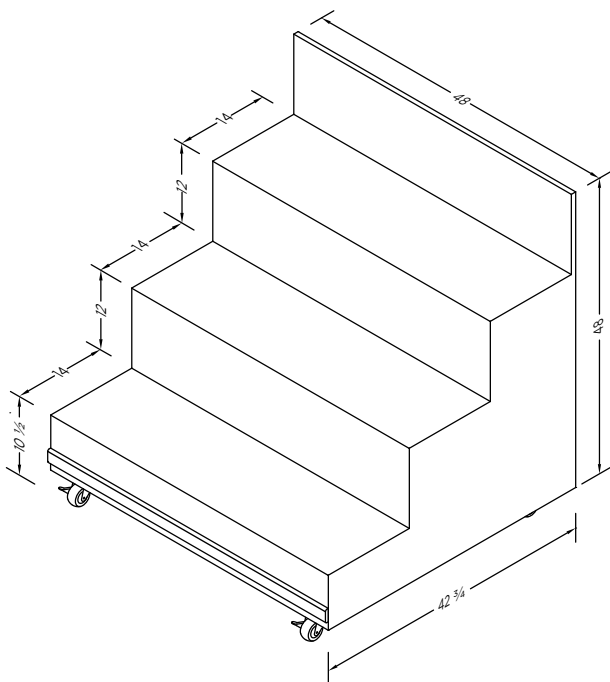

ST3S-002-01B

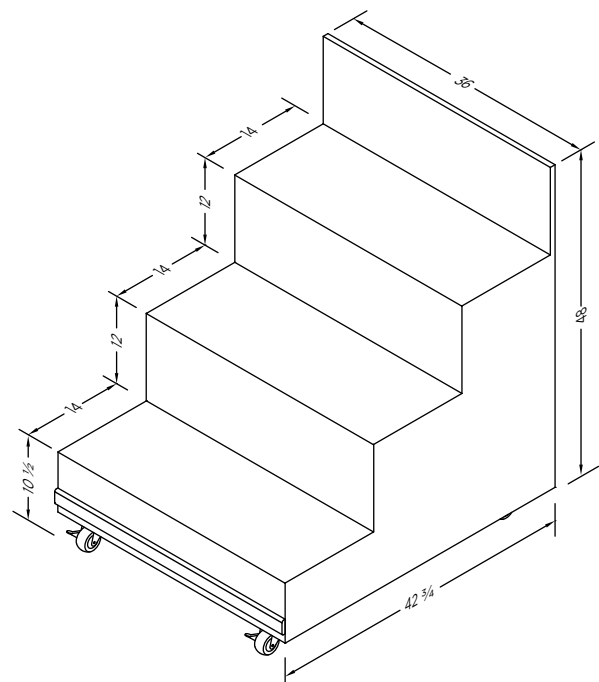

ST3S-002-02B

NESTING TABLE SET



MODEL	DESCRIPTION	LENGTH	DEPTH	HEIGHT
TBST-004-01B	3 Piece Nesting Table Set			
TBFL-007-01B	Nesting Table - Large	48"	14"	30"
TBFL-008-01B	Nesting Table - Medium	42"	14"	25"
TBFL-009-01B	Nesting Table - Small	36"	14"	20"

FEATURES:

- Solid maple construct with galvanized pan inserts
- Tack glides

OPTIONS:

- Stain Finishes - see page 27

Note: Information and specifications may change due to engineering improvements.

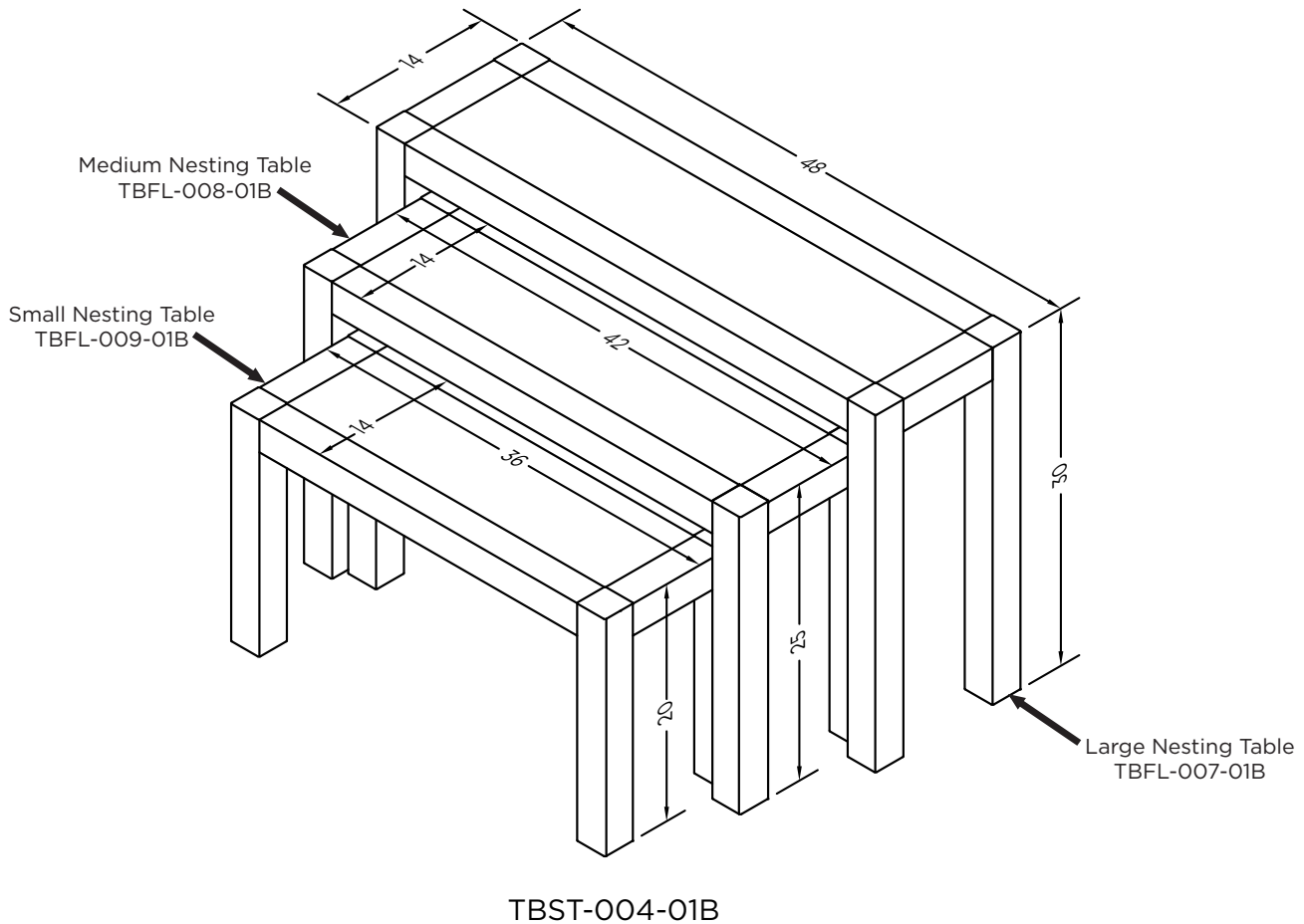

NESTING TABLE SET w/ GALVANIZED TOP



MODEL	DESCRIPTION	LENGTH	DEPTH	HEIGHT
TBST-005-01B	3 Piece Nesting Table Set			
TBFL-010-01B	Nesting Table - Large	30 1/8"	15 3/4"	32"
TBFL-011-01B	Nesting Table - Medium	24 3/8"	15 3/4"	22"
TBFL-012-01B	Nesting Table - Small	18 3/8"	15 3/4"	12"

FEATURES:

- Birch/maple plywood and solid maple construct
- Galvanized tops
- Tack glides

OPTIONS:

- Stain Finishes - see page 27

Note: Information and specifications may change due to engineering improvements.

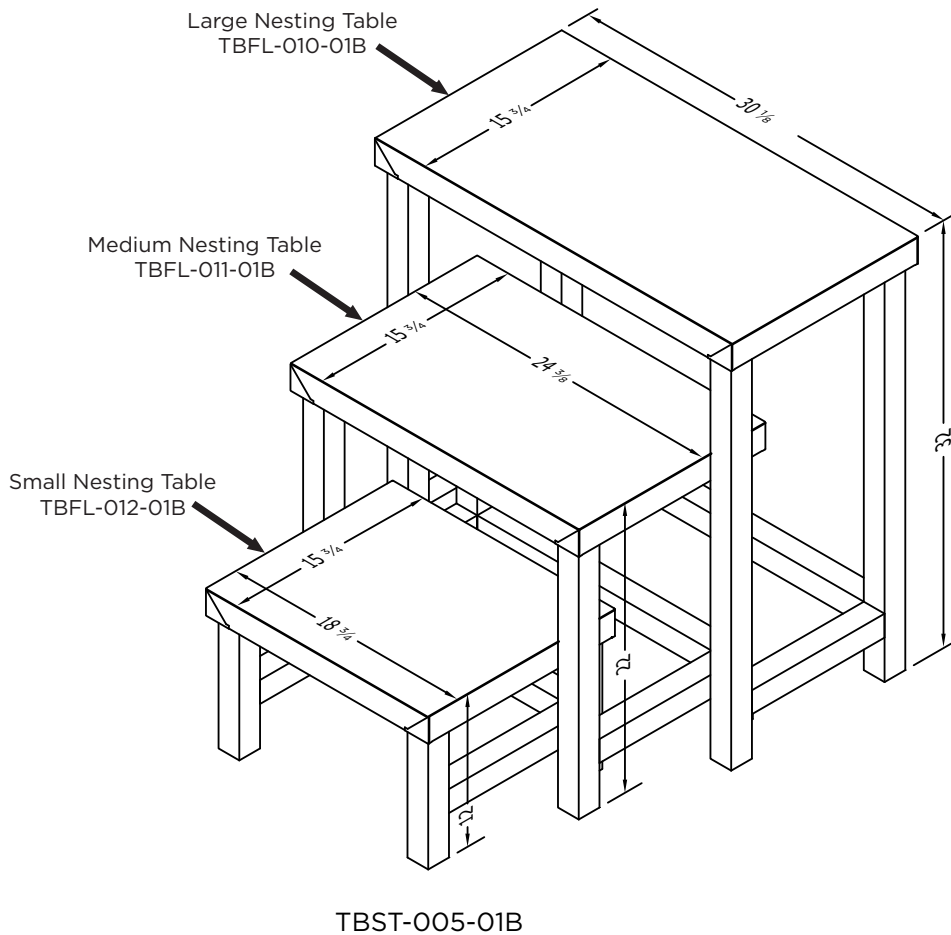

FLORAL WALL SHELVING



MODEL	DESCRIPTION	LENGTH	DEPTH	HEIGHT
SDSW-001-01B	Floral Wall Shelving - Center	43 1/4"	24 3/4"	72"
SDSW-001-01C	Floral Wall Shelving - LH	44"	24 3/4"	72"
SDSW-001-01D	Floral Wall Shelving - RH	44"	24 3/4"	72"

FEATURES:

- Birch/maple plywood & laminate construct
- Slatwall with metal inserts
- ABS bumper
- Metal slatwall shelves

OPTIONS:

- Stain Finishes - see page 27

Note: Information and specifications may change due to engineering improvements.

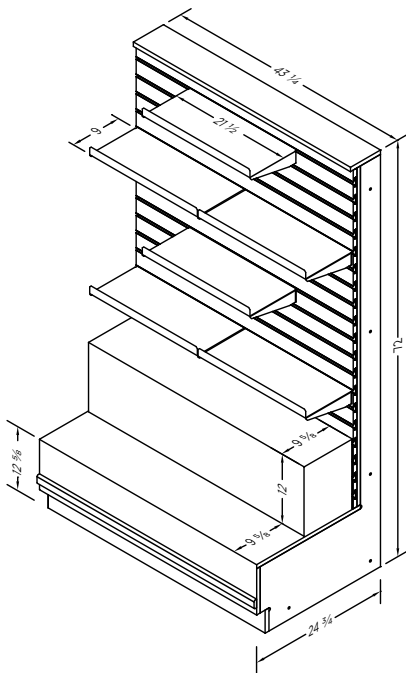

SDSW-001-01B

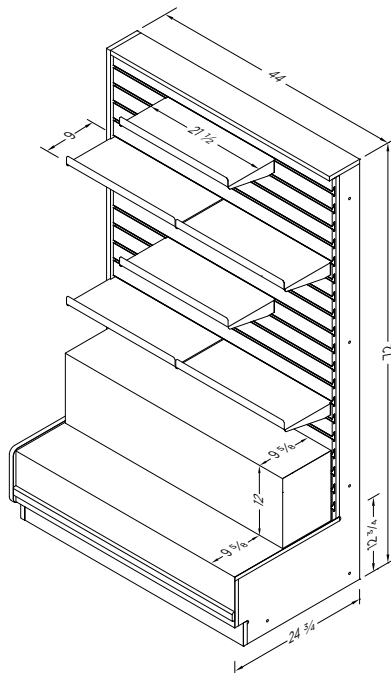

SDSW-001-01C

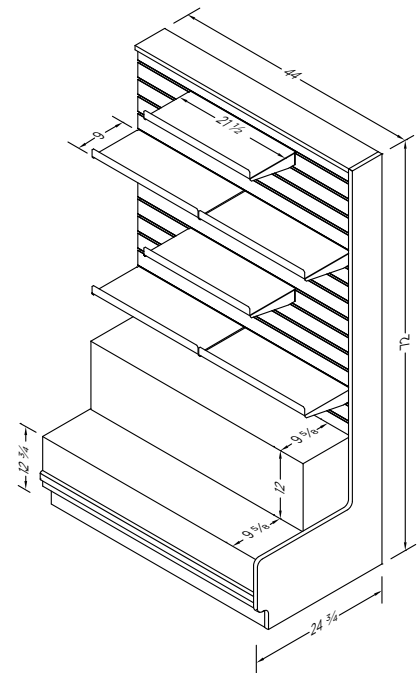

SDSW-001-01B

FLORAL TOWER



MODEL	DESCRIPTION	LENGTH	DEPTH	HEIGHT
SDSA-009-01B	Floral Tower - Small	24"	24"	83 ¼"
SDSA-010-01B	Floral Tower - Large	30"	30"	83 ¼"

FEATURES:

- Birch/maple plywood & solid maple construct
- Adjustable shelves on pilasters
- Protective leg caps & levelers
- SDSA-009-01B galvanized pan & wire mesh

OPTIONS:

- Stain Finishes - see page 27

Note: Information and specifications may change due to engineering improvements.

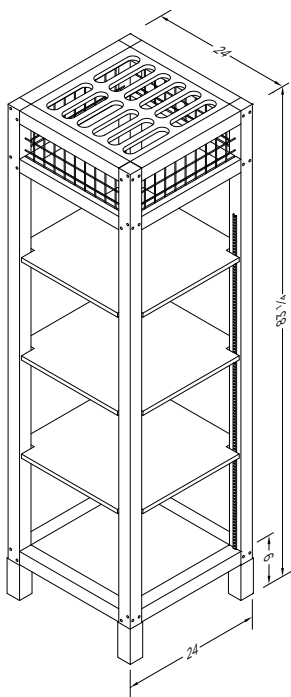

SDSA-009-01B

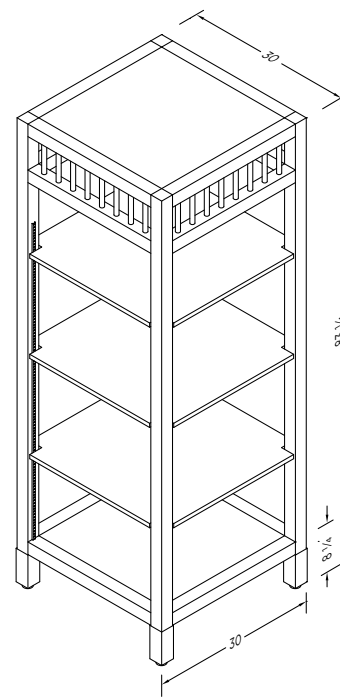

SDSA-010-01B

WRAPPING STATION CARTS



MODEL	DESCRIPTION	LENGTH	DEPTH	HEIGHT
CRWS-001-01B	Floral Wrapping Cart	37"	23"	36"
CRWS-002-01B	Floral Wrapping Cart w/ Bag holder	37"	23"	53"

FEATURES:

- Birch/maple plywood, melamine drawers & laminated counter top construct
- Heavy duty casters (2 locking)
- 2 fixed shelves & pull out lower shelf
- Cellophane roll dispenser holder & wrapping paper holder (CRWS-002-01B)
- ABS bumper

OPTIONS:

- Finishes - see pages 27

Note: Information and specifications may change due to engineering improvements.

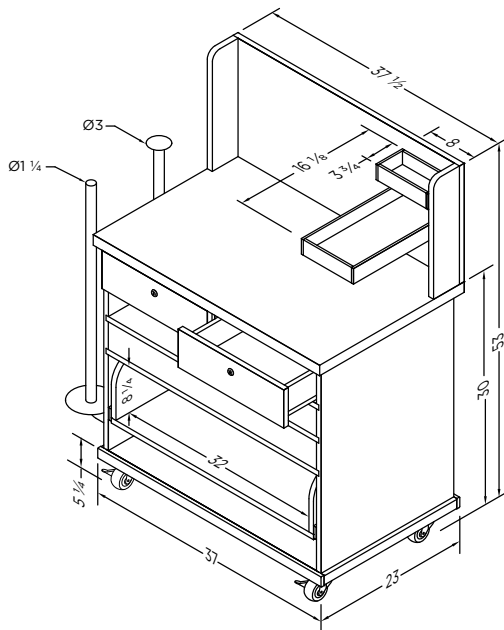

CRWS-002-01B

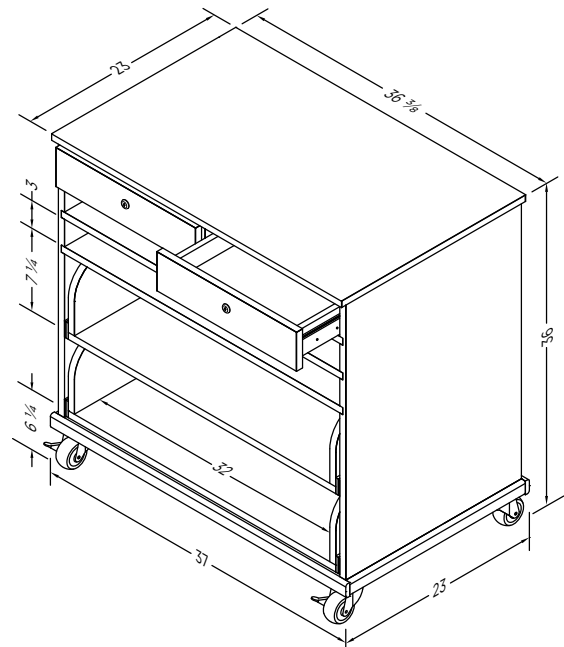

CRWS-001-01B

FLORAL DISPLAY - 3 TIERED



MODEL	DESCRIPTION	LENGTH	DEPTH	HEIGHT
SPFL-001-01B	Floral Display - 3 Tiered	36 1/8"	30"	48"

FEATURES:

- Birch/maple plywood and solid pine construction with metal cladding
- Heavy duty locking casters
- Designed to work with $\text{Ø } 9 \frac{1}{2}'' \times 10 \frac{1}{4}''$ floral bucket (buckets sit approx. $3 \frac{1}{2}''$ above deck level)

floral buckets not supplied

OPTIONS:

- Stain Finishes - see page 27

Note: Information and specifications may change due to engineering improvements.

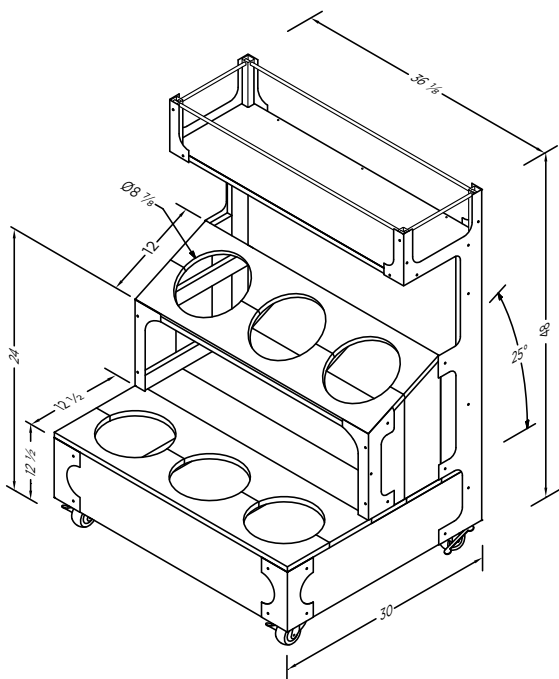

SPFL-001-01B