



BAKERY

COLLECTION

 **Cayuga** DISPLAYS

PASTRY & BUN BIN DISPLAY

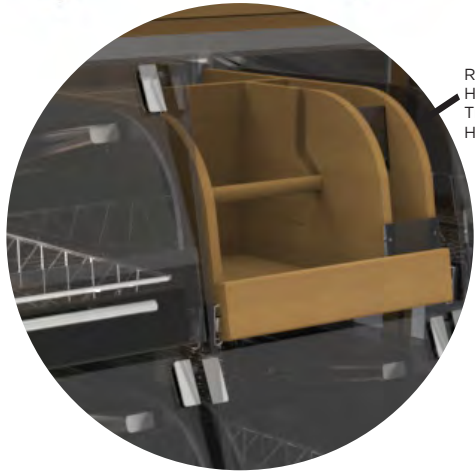

Roll Bag Holder w/ Tie & Pencil Holder

MODEL	DESCRIPTION	LENGTH	DEPTH	HEIGHT
BFBB-005-01B	Pastry & Bun Bin Display - 48"	48"	27 1/4"	55 5/8"
BFBB-005-02B	Pastry & Bun Bin Display - 36"	32 5/8"	27 1/4"	55 5/8"

FEATURES:

- Birch/maple plywood, glass & solid maple construction
- Heavy duty casters (2 locking)
- Pull out drawers w/ metal baskets, tong holders, tongs & tether cords
- Base Storage
- Crumb trays
- LED rear lighting

OPTIONS:

- Roll bag holder
- Refer to Category C for Stain Finishes

Note: Information and specifications may change due to engineering improvements.

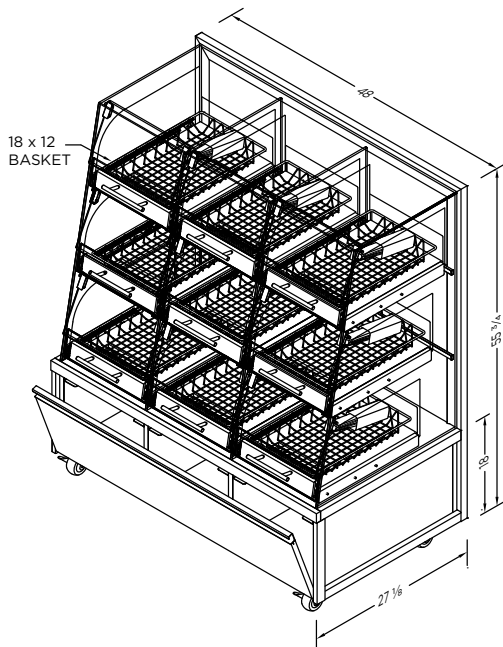

BFBB-005-01B

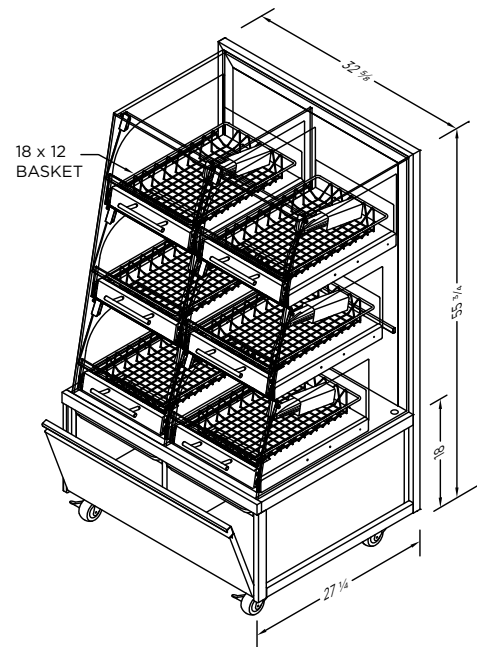

BFBB-005-02B

BULK BIN DISPLAY



MODEL	DESCRIPTION	LENGTH	DEPTH	HEIGHT
BFBB-001-01B	Bulk Bun Display - 4 Tiered	47 1/2"	30 1/8"	64 5/8"
BFBB-002-01B	Bulk Bun Display - 3 Tiered	47 1/2"	26"	53 7/8"

FEATURES:

- Birch/maple plywood, melamine & solid maple construction
- T-mould edges
- Acrylic lids, tong holders, tongs & tether cords
- Crumb tray

OPTIONS:

- Refer to Category C for Stain Finishes

Note: Information and specifications may change due to engineering improvements.

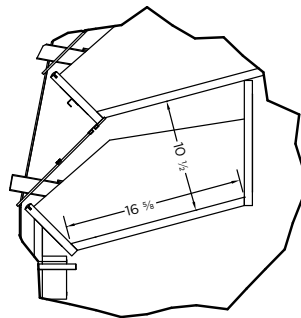

DETAIL D
SCALE 1 / 8

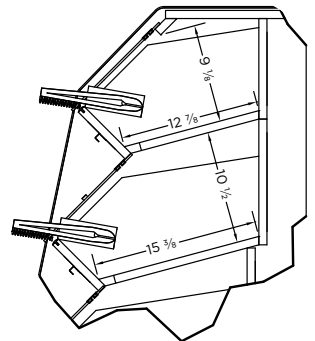

DETAIL B
SCALE 1 / 8

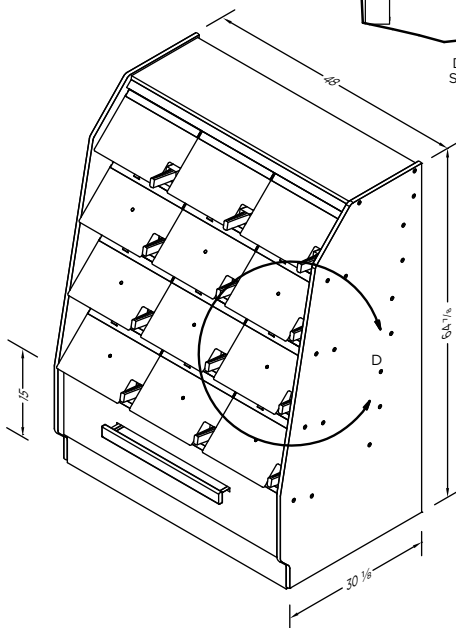

BFBB-001-01B

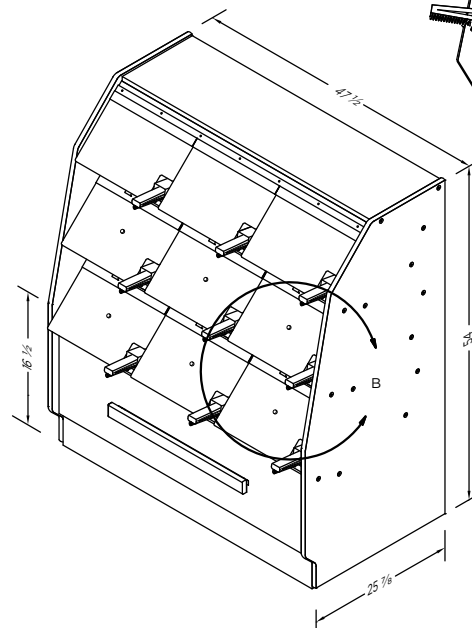

BFBB-002-01B

BUN BIN - TWO TIER



MODEL	DESCRIPTION	LENGTH	DEPTH	HEIGHT
BFBB-003-01B	Two Tier Bun Bin - Single Sided	48"	32"	54 3/8"
BFBB-004-01B	Two Tier Bun Bin - Double Sided	46 1/2"	47 1/2"	47 3/4"

FEATURES:

- Birch/maple plywood, melamine & solid maple construction
- Non-locking casters, ABS bumper & bag holder w/ tie cup
- Acrylic bins with tong holder, tongs, tether cord
- Base storage (BFBB-003-01B)

OPTIONS:

- McCue bumper (1" or 2")
- Refer to Category C for Stain Finishes

Note: Information and specifications may change due to engineering improvements.

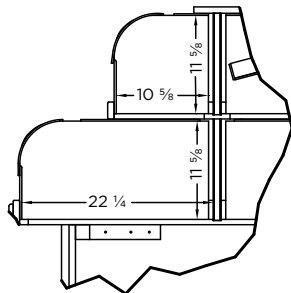

DETAIL F
SCALE 1 / 12

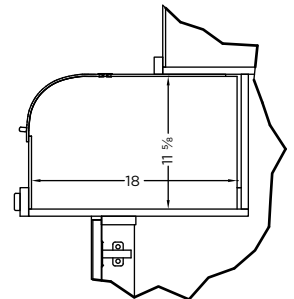

DETAIL B
SCALE 1 / 8

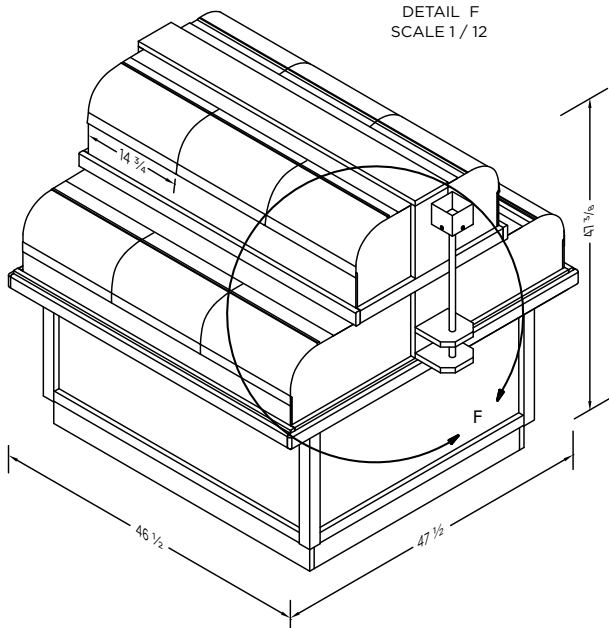

BFBB-004-01B

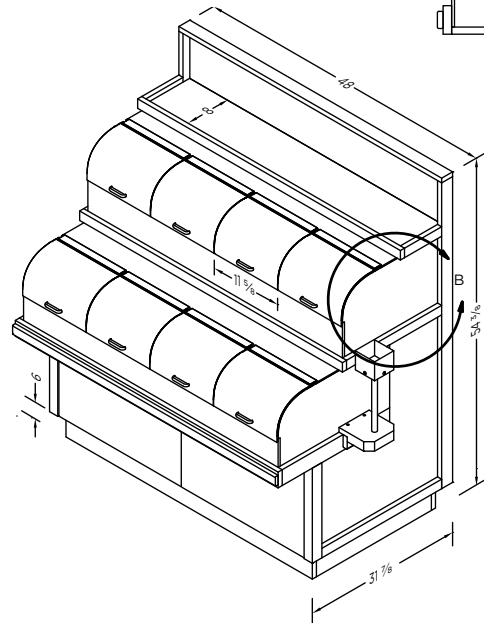

BFBB-003-01B

ISLAND BUN BIN - SINGLE TIER



MODEL	DESCRIPTION	LENGTH	DEPTH	HEIGHT
TBST-008-01B	Single Tier Island Bun Bin - 36"	36"	36"	39"
TBST-009-01B	Single Tier Island Bun Bin - 48"	48"	48"	39"

FEATURES:

- Birch/maple plywood, melamine & solid maple construction
- Removable bins for easy cleaning
- Tong holders, tongs and tethers
- Levelers

OPTIONS:

- Refer to Category C for Stain Finishes

Note: Information and specifications may change due to engineering improvements.

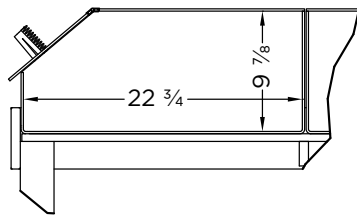

DETAIL B
SCALE 1 / 12

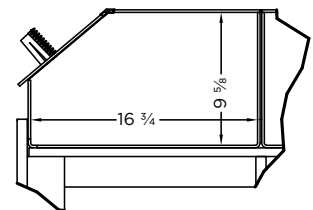

DETAIL B
SCALE 1 / 8

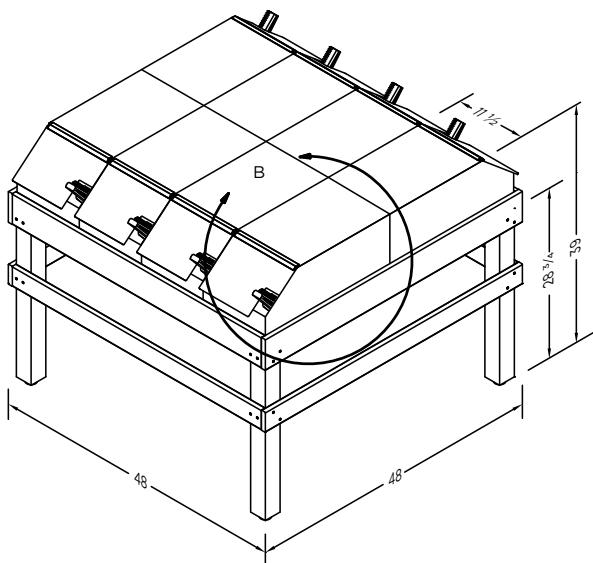

TBST-009-01B

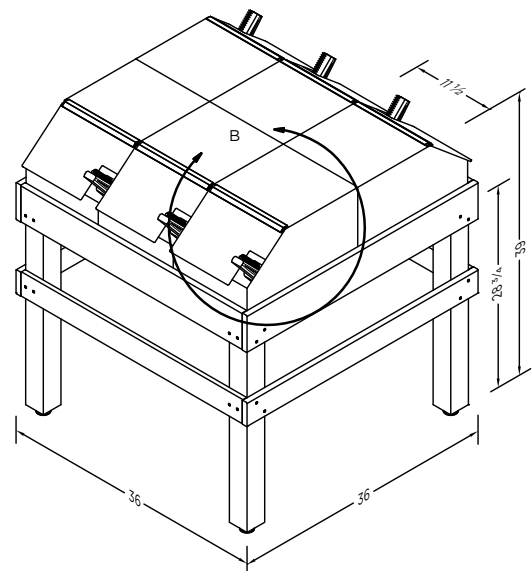

TBST-008-01B

BAGUETTE DISPLAYS



MODEL	DESCRIPTION	LENGTH	DEPTH	HEIGHT
SDBG-001-01B	Baguette Display - 2 Tiered	50 7/8"	26 5/8"	55"
SDBG-002-01B	Baguette Display - 3 Tiered	36 7/8"	26"	37 1/2"
SDBG-005-01B	Baguette Display	15 3/4"	18"	59 1/8"

FEATURES:

- Birch/maple plywood and solid maple construction

SDBG-001-01B & SDBG-002-01B

- 2" ABS bumper
- Heavy duty locking casters
- Metal baguette baskets

SDBG-005-01B

- Wicker baguette baskets

OPTIONS:

- ABS bumper (1 1/2")
- McCue bumper (1" or 2")
- Refer to Category C for Stain Finishes

Note: Information and specifications may change due to engineering improvements.

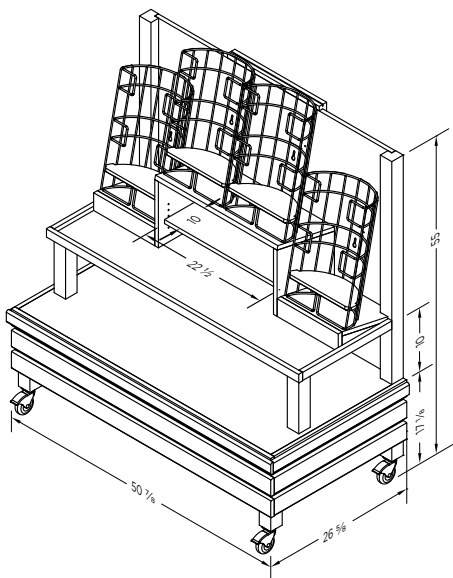

SDBG-001-01B

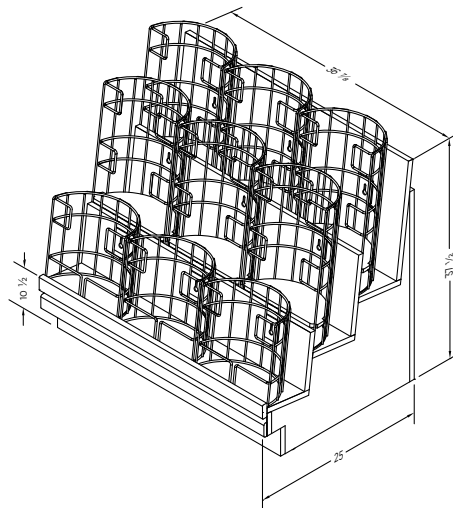

SDBG-002-01B

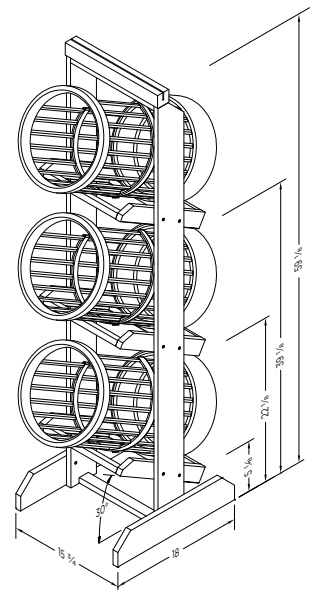

SDBG-005-01B

WALKAROUND SHELVING DISPLAY



MODEL	DESCRIPTION	LENGTH	DEPTH	HEIGHT
SDIM-004-01B	Walkaround Shelving Display - Small	24"	24"	60 3/8"
SDIM-005-01B	Walkaround Shelving Display - Tall w/Lg Shelf	28"	28"	68 3/8"
SDIM-006-01B	Walkaround Shelving Display - Tall w/Sm Shelf	24"	24"	68 3/8"

FEATURES:

- Birch/maple plywood & solid maple construction
- Heavy duty locking casters
- 2" ABS bumper
- Adjustable shelves
- Sign holder (chalkboard w/ J-channel & snap track)

OPTIONS:

- McCue bumper (2")
- Protective corner guards
- Refer to Category C for Stain Finishes

Note: Information and specifications may change due to engineering improvements.

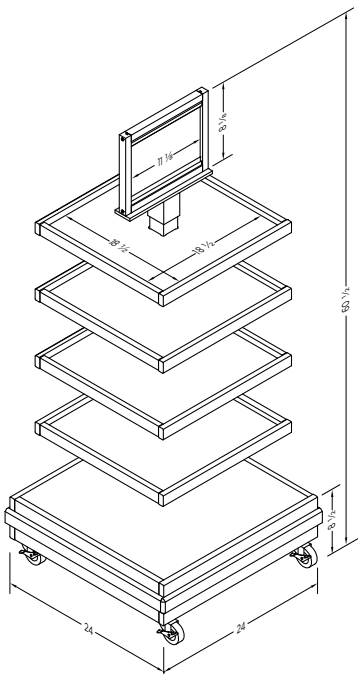

SDIM-004-01B

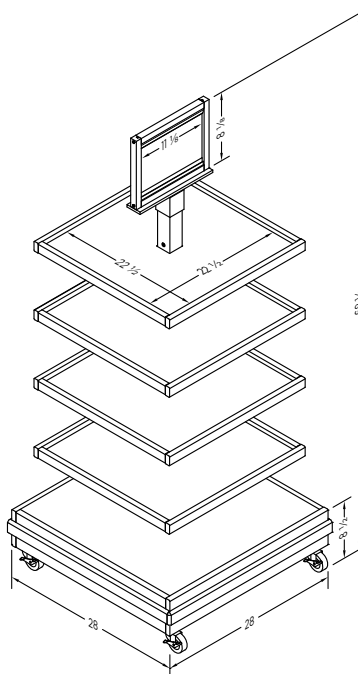

SDIM-005-01B

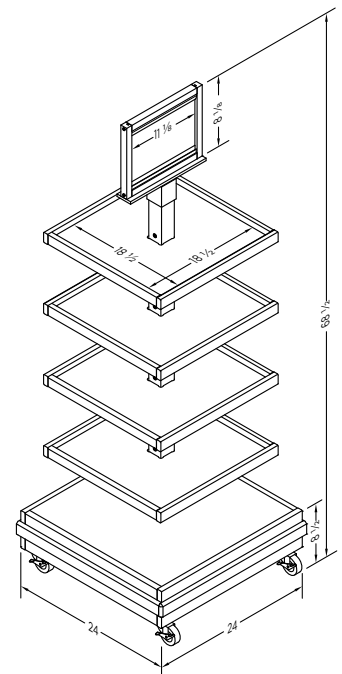

SDIM-006-01B

TIERED MERCHANDISING TABLE



MODEL	DESCRIPTION	LENGTH	DEPTH	HEIGHT
TBIM-004-01B	Tiered Merchandising Table - Small	30"	30"	54 ¼"
TBIM-004-02B	Tiered Merchandising Table - Large	47 ½"	30"	54 ¼"

FEATURES:

- Birch/maple plywood & solid maple construction
- Locking casters
- Corner Guards
- Bumper

OPTIONS:

- Refer to Category C for Stain Finishes

Note: Information and specifications may change due to engineering improvements.

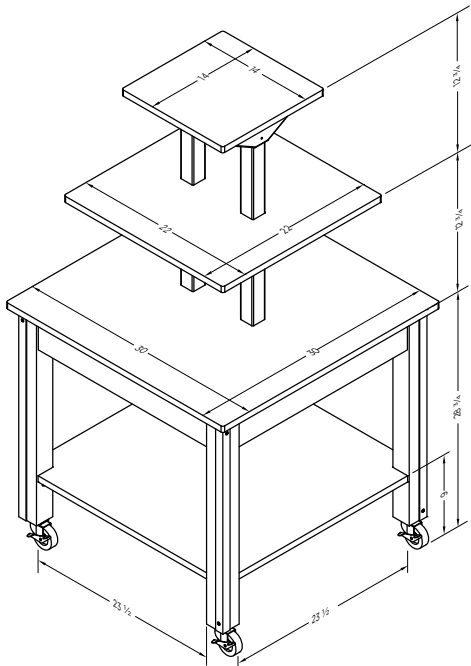

TBIM-004-01B

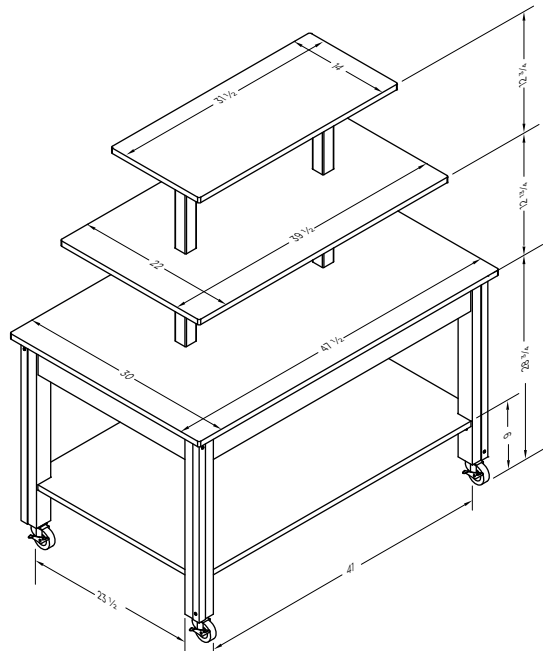

TBIM-004-02B

NESTING TABLE SET



MODEL	DESCRIPTION	LENGTH	DEPTH	HEIGHT
TBST-001-01C	7 Piece Nesting Table Set			
TBHV-001-01B	Nesting Table - Large	36"	36"	35"
TBHV-002-01B	Nesting Table - Small	27"	27"	28"
TBHV-004-01B	Bench Table	48"	12"	28"
ACRI-007-01A	Riser	36"	14"	7"

FEATURES:

- Birch/maple plywood & solid maple construction
- Levelers
- Protective leg caps

OPTIONS:

- ABS bumper (1 ½" or 2")
- McCue bumper (1" or 2")
- Protective corner guards
- Refer to Category C for Stain Finishes

Note: Information and specifications may change due to engineering improvements.

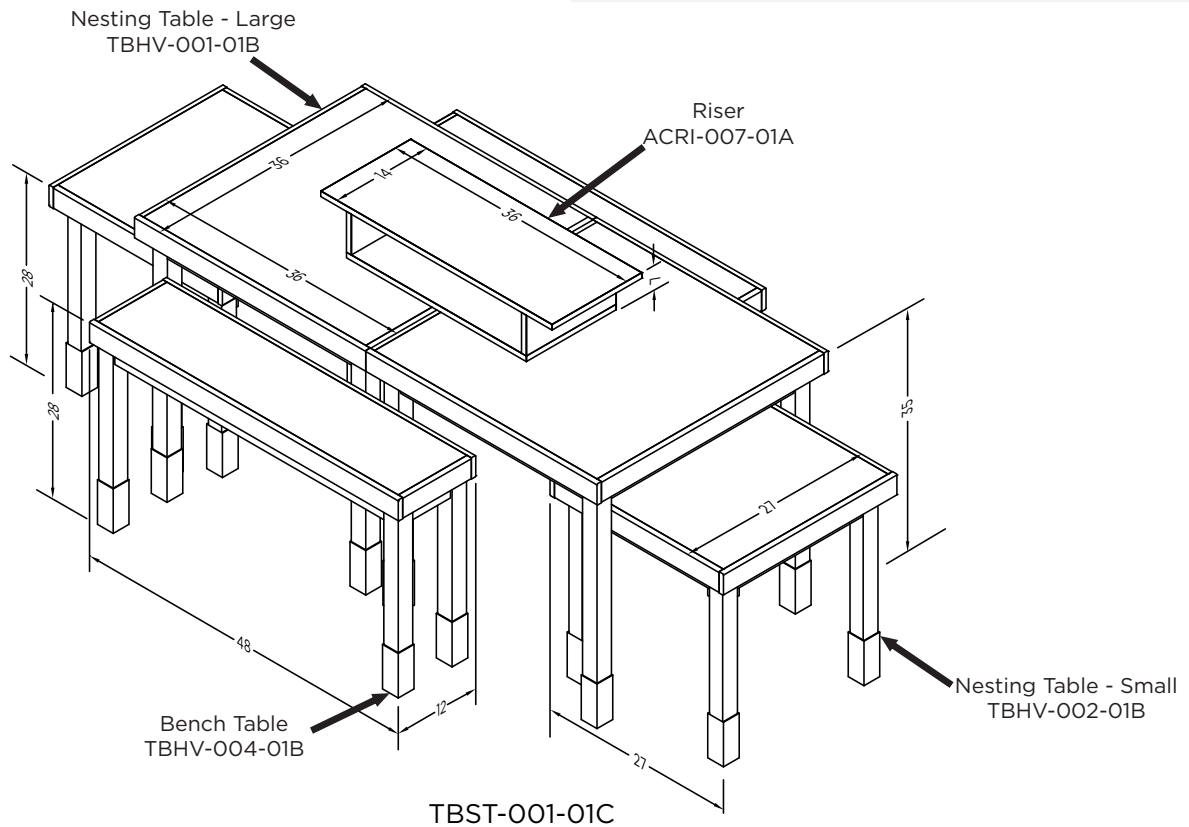

NESTING TABLE SET



MODEL	DESCRIPTION	LENGTH	DEPTH	HEIGHT
TBST-001-01B	2 Piece Nesting Table Set			
TBHV-005-01B	Nesting Table - Large	36"	36"	29 ½"
TBHV-006-01B	Nesting Table - Small	27"	27"	23 ½"

FEATURES:

- Birch/maple plywood & solid maple construction
- Levelers
- Protective leg caps

OPTIONS:

- ABS bumper (1 ½" or 2")
- McCue bumper (1" or 2")
- Protective corner guards
- Refer to Category C for Stain Finishes

Note: Information and specifications may change due to engineering improvements.

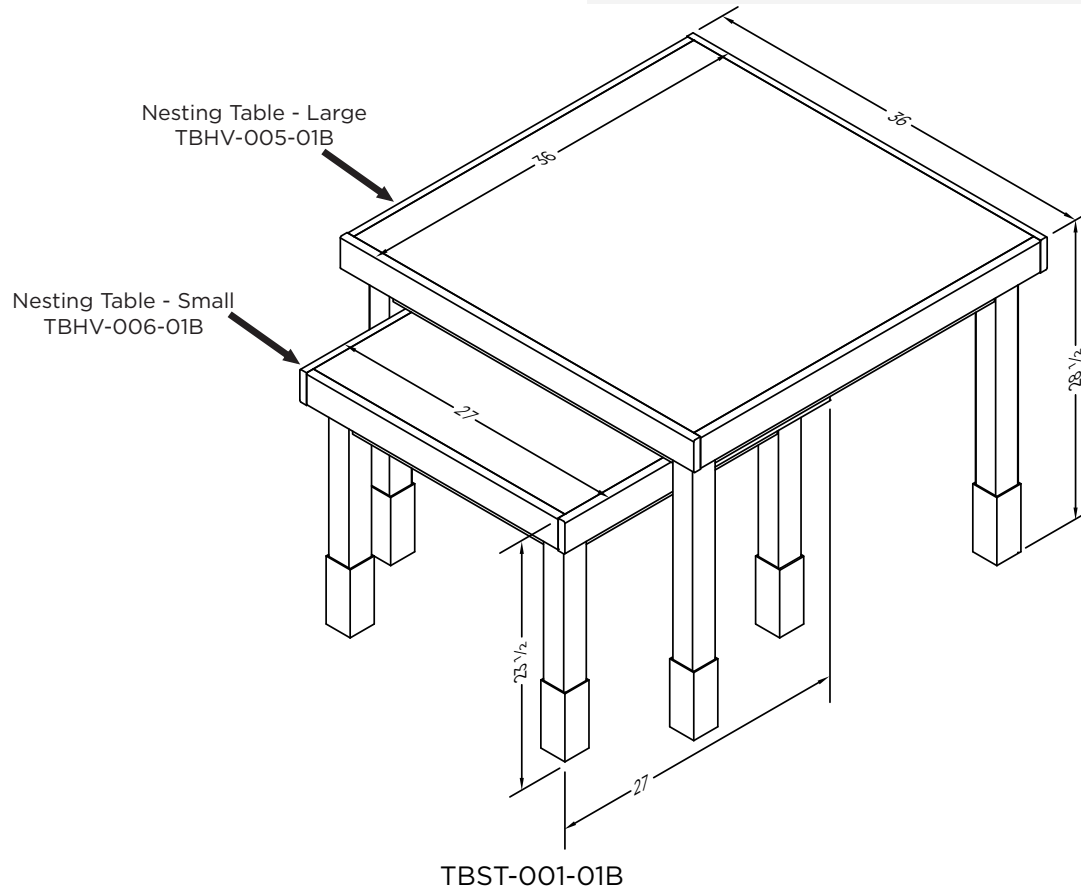

NESTING TABLE SET



MODEL	DESCRIPTION	LENGTH	DEPTH	HEIGHT
TBST-002-01B	8 Piece Nesting Table Set			
TBHV-007-01B	Nesting Table - Large	47 7/8"	47 7/8"	35 1/2"
TBHV-008-01B	Nesting Table - Medium	37 7/8"	27 7/8"	29 3/4"
TBHV-009-01B	Nesting Table - Small	27 7/8"	27 7/8"	21 3/4"
TBIM-003-01B	Side Shelving Table	35 1/2"	18 1/4"	35 1/2"
ACRI-007-01A	Riser	18"	12"	10"

FEATURES:

- Birch/maple plywood & solid maple construction
- Levelers

OPTIONS:

- ABS bumper (1 1/2" or 2")
- McCue bumper (1" or 2")
- Protective leg caps
- Protective corner guards
- Refer to Category C for Stain Finishes

Note: Information and specifications may change due to engineering improvements.

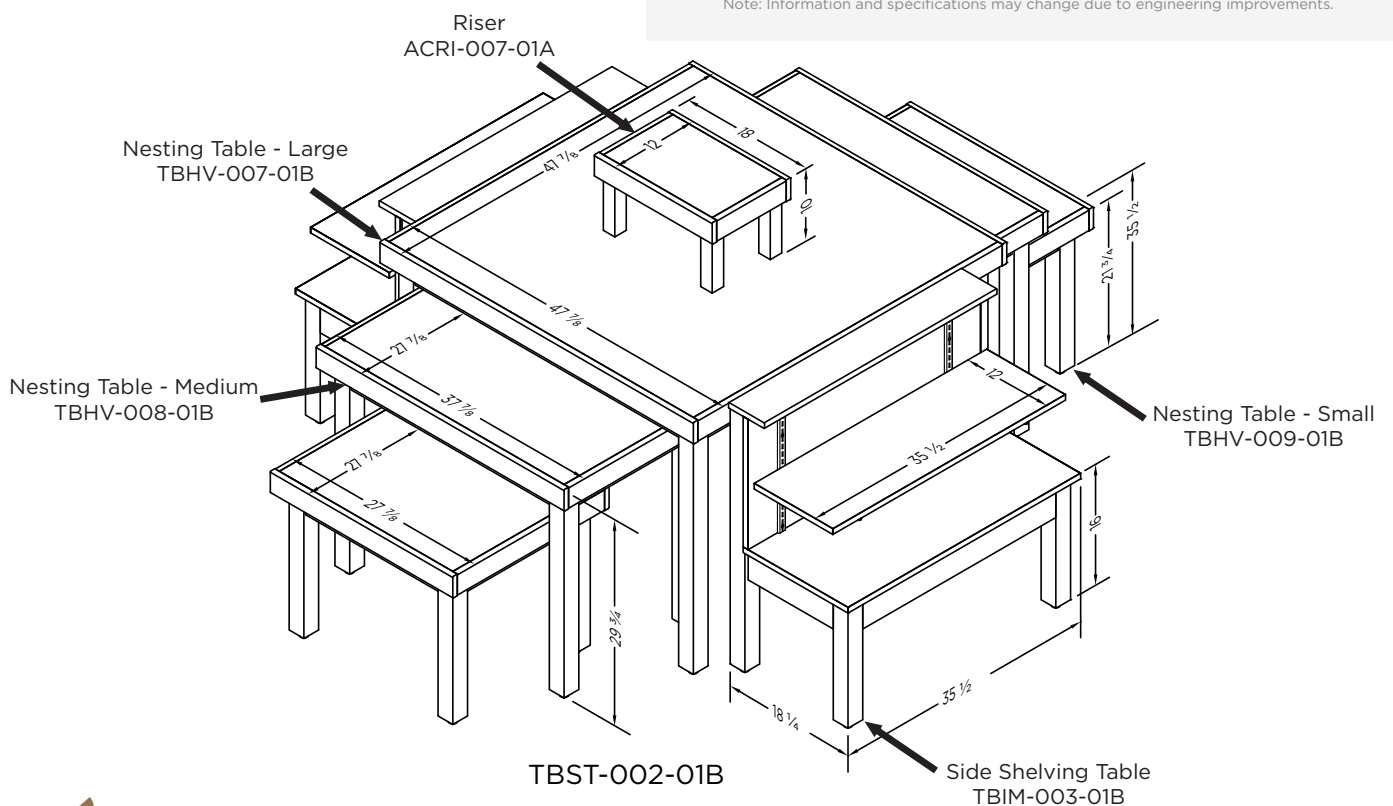

NESTING TABLE SET



MODEL	DESCRIPTION	LENGTH	DEPTH	HEIGHT
TBST-003-01B	3 Piece Nesting Table Set			
TBHV-010-01B	Nesting Table - Large	48"	24"	36"
TBIM-002-01B	Nesting Table w/ Shelf - Small	40"	19"	30"

FEATURES:

- Birch/maple plywood & solid maple construction
- Levelers
- Metal cross-support
- Protective leg caps

OPTIONS:

- ABS bumper (1 ½" or 2")
- McCue bumper (1" or 2")
- Refer to Category C for Stain Finishes

Note: Information and specifications may change due to engineering improvements.

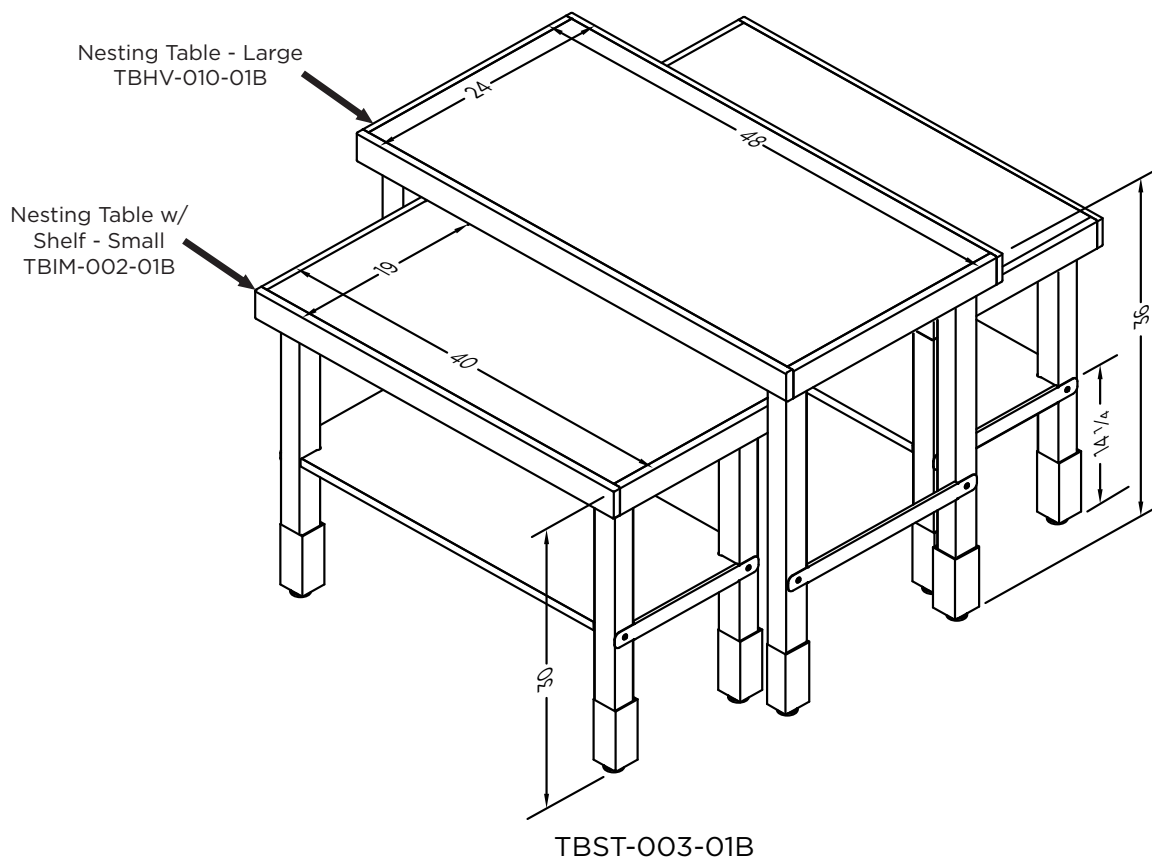

MOBILE BAKERY RACKS



MODEL	DESCRIPTION	LENGTH	DEPTH	HEIGHT
SDIM-001-01B	Mobile Bakery Racks - Large	28"	20"	77 1/8"
SDIM-002-01B	Mobile Bakery Racks - Small	22"	20"	66 1/8"

FEATURES:

- Solid maple construction
- Locking casters
- Adjustable shelves

OPTIONS:

- ABS bumper (1 1/2" or 2")
- McCue bumper (1" or 2")
- Refer to Category C for Stain Finishes

Note: Information and specifications may change due to engineering improvements.

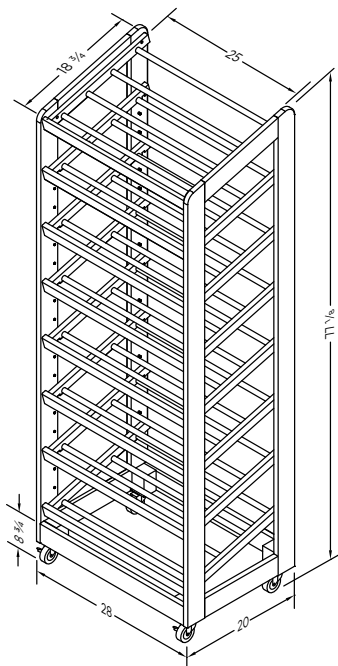

SDIM-001-01B

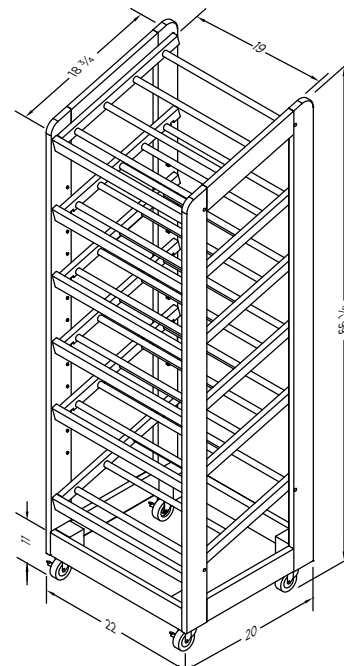

SDIM-002-01B