



# PRODUCE

COLLECTION

**Cayuga** DISPLAYS



# DEPARTMENT: PRODUCE

**The produce department is the single greatest determiner of customer loyalty. More than just showcasing fresh product, the produce area needs to have a fresh overall energy too, with plentiful displays and great range of product.**

Cayuga Displays has an extensive line of display possibilities to highlight the produce itself, as well as to cross-merchandise related products, like dried fruits, sauces and nuts. We offer great options for getting more refrigeration on your floor in order to build your customers' shopping experiences and get more product noticed.

And when you work with Cayuga Displays, you can always be confident we'll help you to select the right product and options, so that you have the food presentation that is certain to elevate your customers' experience and enhance your brand - beautifully.

*"Longos is pleased to support Cayuga Displays. Your team's quick service/turnaround for projects has helped us with our millwork for bakery and floral in past projects. More recently your team has come up with some cost effective refrigeration solutions for our bakery and produce."*

Paul Collette,  
Longo's Support Center  
Project Manager Real Estate  
and Construction

# FIXTURES

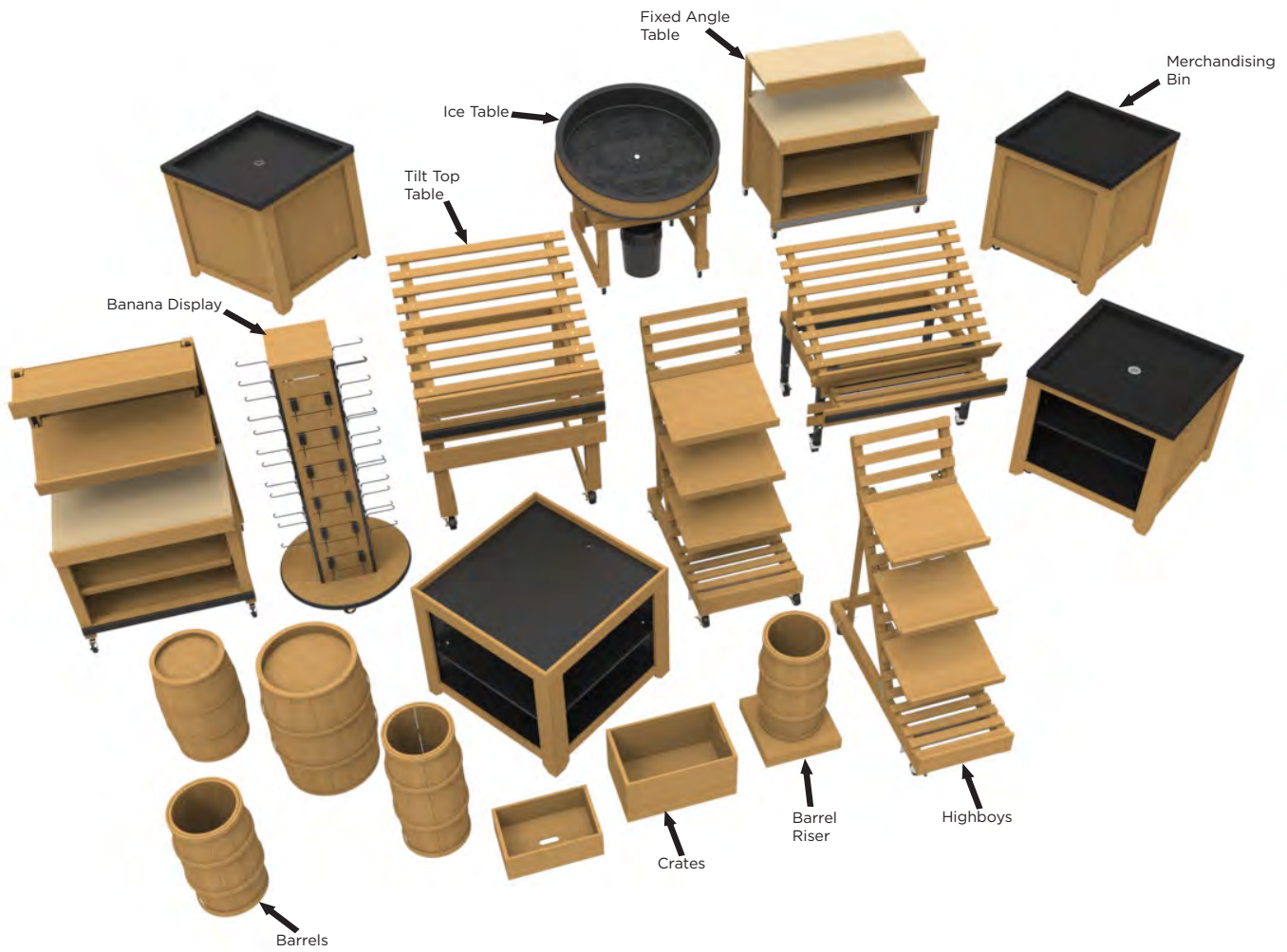

# ROUND DISPLAY TABLE



| MODEL        | DESCRIPTION              | LENGTH | DEPTH | HEIGHT |
|--------------|--------------------------|--------|-------|--------|
| TBOR-001-01B | Round Tilt-Top Ice Table | 44"Ø   | -     | 35 ½"± |

## FEATURES:

- Birch/maple plywood and solid maple construction
- Heavy duty casters (2 locking)
- Insulated ABS tub with drain, ball valve, hose and bucket
- T-mold bumper
- Tilt-top deck
- Use dry, with water or ice

## OPTIONS:

- Levelers
- Stain Finishes - see page 68

Note: Information and specifications may change due to engineering improvements.

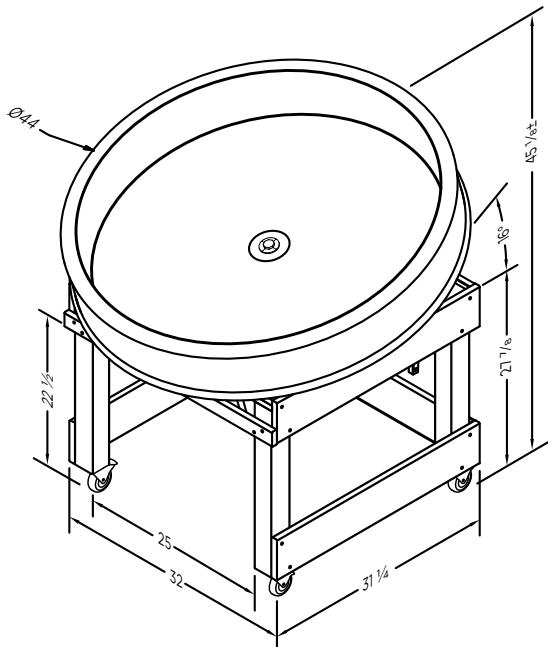

TBOR-001-01B

# MERCHANDISING BIN - PALLET STYLE



| MODEL        | DESCRIPTION                      | LENGTH  | DEPTH   | HEIGHT |
|--------------|----------------------------------|---------|---------|--------|
| TBOR-002-01B | Merchandising Bin - Pallet Style | 35 1/2" | 35 1/2" | 32"    |

## FEATURES:

- Birch/maple plywood and solid maple construction
- Heavy duty locking casters
- ABS liner

## OPTIONS:

- Stain Finishes - see page 68

Note: Information and specifications may change due to engineering improvements.

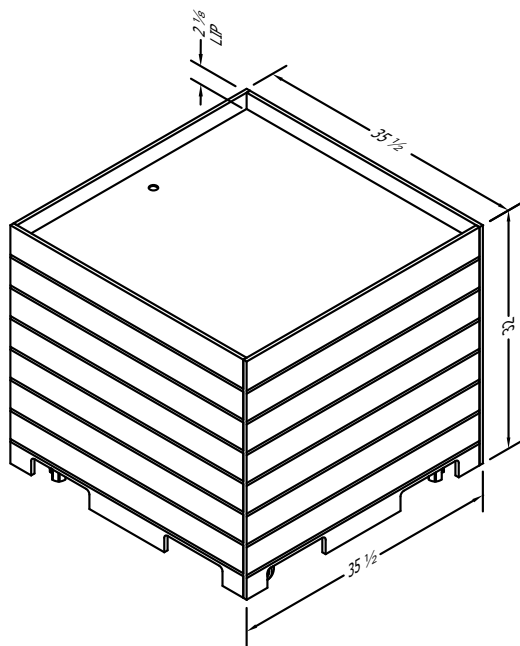

TBOR-002-01B

# MERCHANDISING BINS



| MODEL        | DESCRIPTION                                    | LENGTH  | DEPTH   | HEIGHT  |
|--------------|------------------------------------------------|---------|---------|---------|
| TBOR-012-01B | Merchandising Bin                              | 35 1/2" | 35 1/2" | 31 3/8" |
| TBOR-004-01B | Merchandising Bin - Tall                       | 35 1/2" | 35 1/2" | 35 3/8" |
| TBOR-013-01B | Merchandising Bin w/ ABS Tray w/ drain         | 36"     | 36"     | 31 3/8" |
| TBOR-006-01B | Merchandising Bin w/ ABS Tray w/ drain- Tall   | 36"     | 36"     | 35 3/8" |
| TBOR-012-01C | Merchandising Bin w/ ABS Tray w/o drain        | 36"     | 36"     | 31 3/8" |
| TBOR-004-01C | Merchandising Bin w/ ABS Tray w/o drain - Tall | 36"     | 36"     | 35 3/8" |

## FEATURES:

- Birch/maple plywood and solid maple construction
- Heavy duty locking casters
- ABS tray w/ drain & bucket, ABS tray w/o drain or ABS liner

## OPTIONS:

- Stain Finishes - see page 68

Note: Information and specifications may change due to engineering improvements.

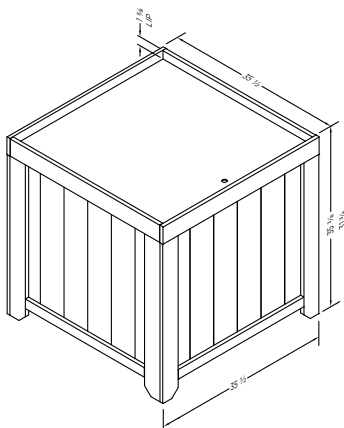

TBOR-004-01B  
TBOR-012-01B

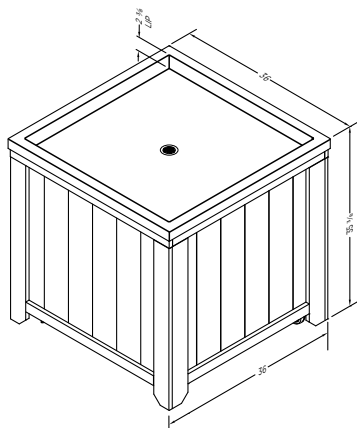

TBOR-006-01B  
TBOR-013-01B

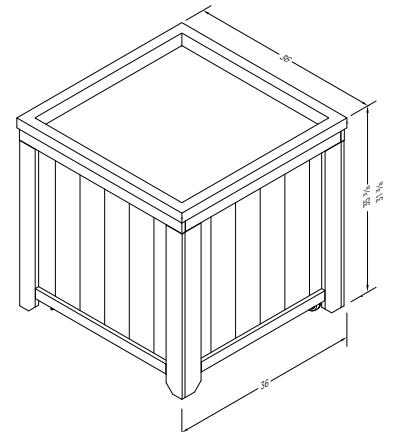

TBOR-004-01C  
TBOR-012-01C

# MERCHANDISING BINS w/ BASE SHELVING



| MODEL        | DESCRIPTION                                                 | LENGTH  | DEPTH   | HEIGHT  |
|--------------|-------------------------------------------------------------|---------|---------|---------|
| TBOR-003-01B | Merchandising Bin w/ Base Shelf                             | 35 1/2" | 35 1/2" | 31 3/8" |
| TBOR-010-01B | Merchandising Bin w/ Base Shelf - Tall                      | 35 1/2" | 35 1/2" | 35 3/8" |
| TBOR-005-01B | Merchandising Bin w/ Base Shelf & ABS Tray w/ drain         | 36"     | 36"     | 31 3/8" |
| TBOR-011-01B | Merchandising Bin w/ Base Shelf & ABS Tray w/ drain - Tall  | 36"     | 36"     | 35 3/8" |
| TBOR-003-01C | Merchandising Bin w/ Base Shelf & ABS Tray w/o drain        | 36"     | 36"     | 31 3/8" |
| TBOR-010-01C | Merchandising Bin w/ Base Shelf & ABS Tray w/o drain - Tall | 36"     | 36"     | 35 3/8" |

## FEATURES:

- Birch/maple plywood, black melamine and solid maple construction
- Heavy duty locking casters
- Adjustable base shelf
- ABS tray w/ drain & bucket, ABS tray w/o drain or ABS liner

## OPTIONS:

- Stain Finishes - see page 68

Note: Information and specifications may change due to engineering improvements.

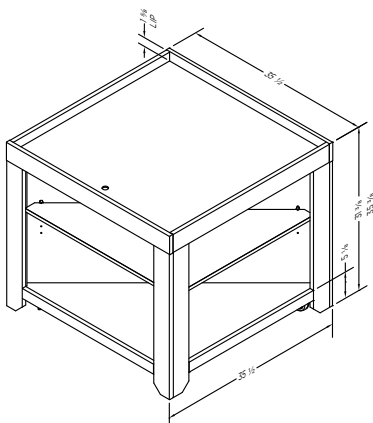

TBOR-003-01B  
TBOR-010-01B

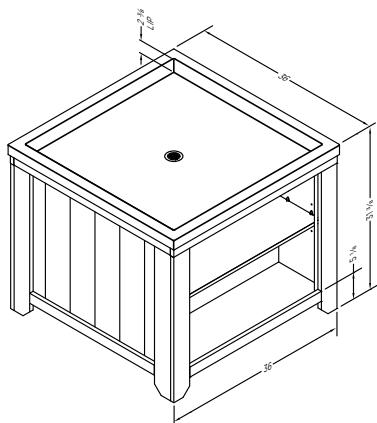

TBOR-005-01B  
TBOR-011-01B

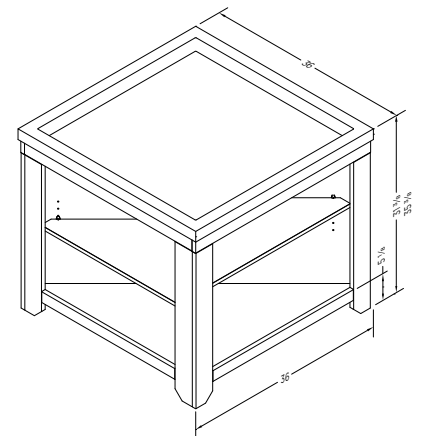

TBOR-003-01C  
TBOR-010-01C

# ACRYLIC BULK BINS

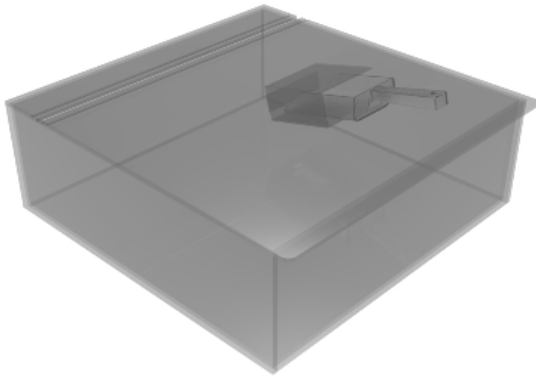

| MODEL        | DESCRIPTION                        | LENGTH  | DEPTH   | HEIGHT |
|--------------|------------------------------------|---------|---------|--------|
| ACBN-001-01B | Acrylic Bin w/ Scoop & Tether Cord | 16 7/8" | 16 7/8" | 6"     |

## FEATURES:

- 1/4" Acrylic bins
- Scoop & tether cord
- Designed to work with Merchandising Bins that have ABS liner only (no ABS tray)

Note: Information and specifications may change due to engineering improvements.

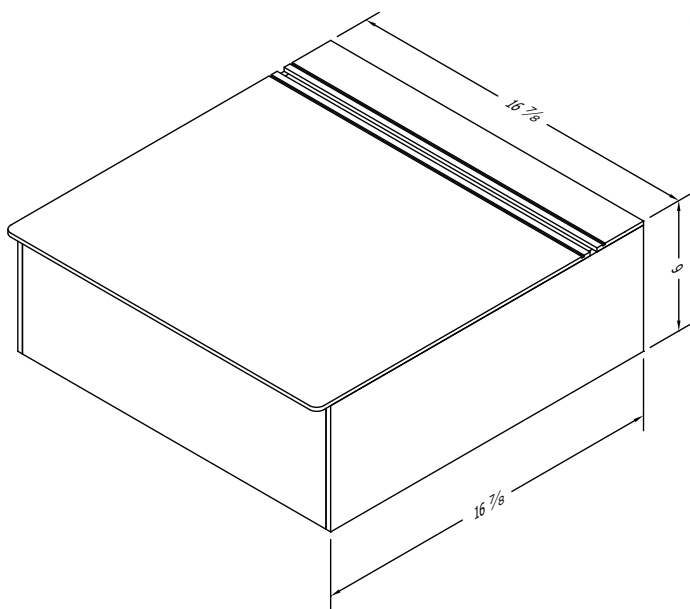

ACBN-001-01B



ACBN-001-01B  
Acrylic Bin w/ Scoop  
& Tether Cord

TBOR-003-01B  
Merchandising Bin w/  
ABS Liner



# REVERSABLE RISER



| MODEL        | DESCRIPTION                     | LENGTH | DEPTH | HEIGHT |
|--------------|---------------------------------|--------|-------|--------|
| ACRI-001-01B | Reversible Riser - Large, Tall  | 24"    | 24"   | 16"    |
| ACRI-001-01C | Reversible Riser - Small, Tall  | 18"    | 18"   | 16"    |
| ACRI-002-01B | Reversible Riser - Large, Short | 24"    | 24"   | 12"    |
| ACRI-002-01C | Reversible Riser - Small, Short | 18"    | 18"   | 12"    |

## FEATURES:

- Birch/maple plywood, wiggle wood, veneer and solid maple construct w/metal legs
- Designed to be reversible, either merchandise on square or round top
- Designed to work with Merchandising bins

## OPTIONS:

- Stain Finishes - see page 68

Note: Information and specifications may change due to engineering improvements.

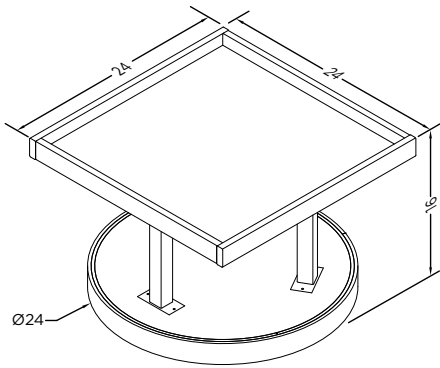

ACRI-001-01B

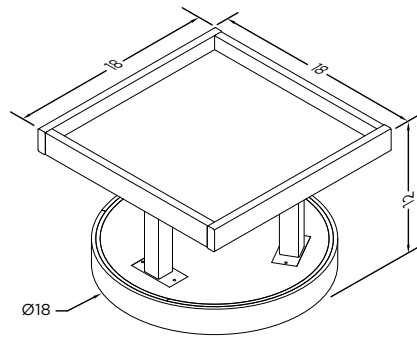

ACRI-002-01C

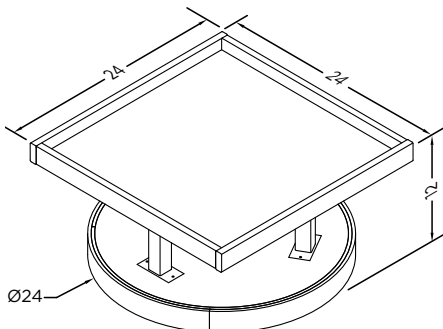

ACRI-002-01B

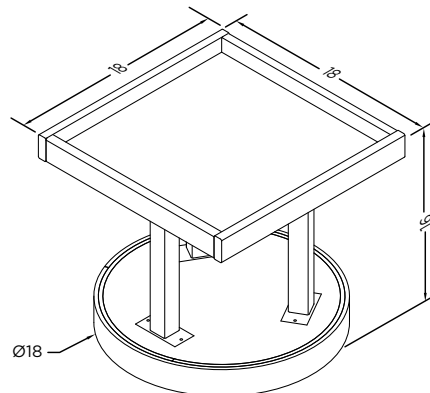

ACRI-001-01C

# BANANA DISPLAY

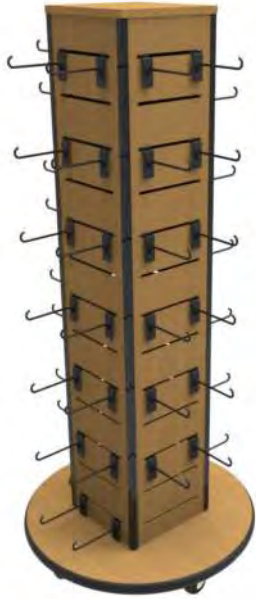

| MODEL        | DESCRIPTION                  | LENGTH | DEPTH | HEIGHT  |
|--------------|------------------------------|--------|-------|---------|
| SPIM-001-01B | Banana Merchandising Display | 28"Ø   | -     | 65 1/2" |

## FEATURES:

- Birch/maple plywood and solid maple construction
- Locking casters
- Protective corner guards
- 6" slat wall hooks
- T-mold bumper

## OPTIONS:

- Stain Finishes - see page 68

Note: Information and specifications may change due to engineering improvements.

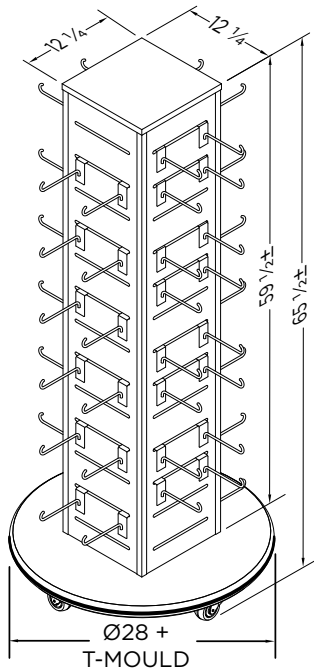

SPIM-001-01B

# NARROW MULTI-TIER TABLE



| MODEL        | DESCRIPTION             | LENGTH  | DEPTH   | HEIGHT  |
|--------------|-------------------------|---------|---------|---------|
| TBFS-001-01B | Narrow Multi-Tier Table | 47 1/2" | 29 3/4" | 45 5/8" |

## FEATURES:

- Birch/maple plywood, MDF and solid maple construction
- Heavy duty casters (2 locking)
- Open base merchandising area
- Adjustable shelf in base area
- 1 1/2" ABS bumper

## OPTIONS:

- McCue bumper (1" or 2")
- Data Strip, sign holder (2 or 3 track)
- Stain Finishes - see page 68

Note: Information and specifications may change due to engineering improvements.

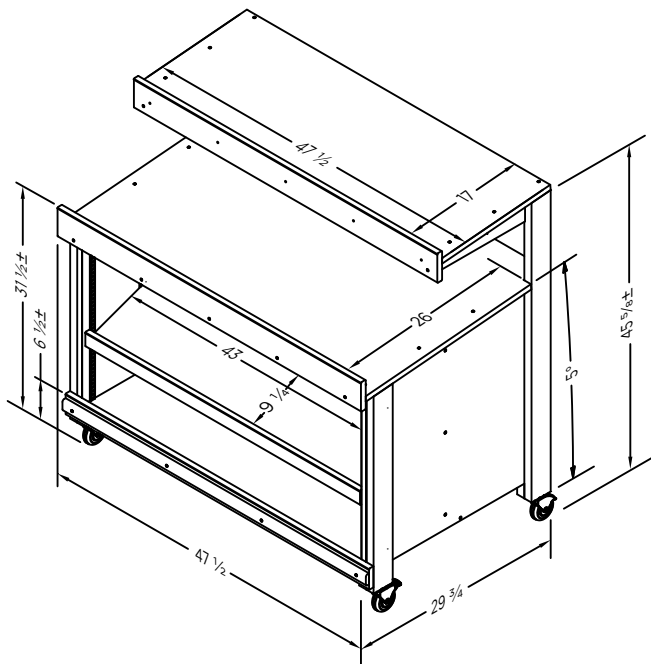

TBFS-001-01B

# NARROW MULTI-SHELF TABLE



| MODEL        | DESCRIPTION             | LENGTH  | DEPTH | HEIGHT |
|--------------|-------------------------|---------|-------|--------|
| TBFS-002-01B | Multi-Shelf Table - 48" | 47 1/2" | 29"   | 55"    |
| TBFS-002-02B | Multi-Shelf Table - 36" | 35 1/2" | 29"   | 55"    |

## FEATURES:

- Birch/maple plywood, MDF and solid maple construction
- Two upper adjustable shelves
- Heavy duty casters (2 locking)
- Open base merchandising area
- Adjustable bottom shelf
- 2" ABS bumper

## OPTIONS:

- McCue bumper (1" or 2")
- 1 1/4" Data Strip
- Stain Finishes - see page 68

Note: Information and specifications may change due to engineering improvements.

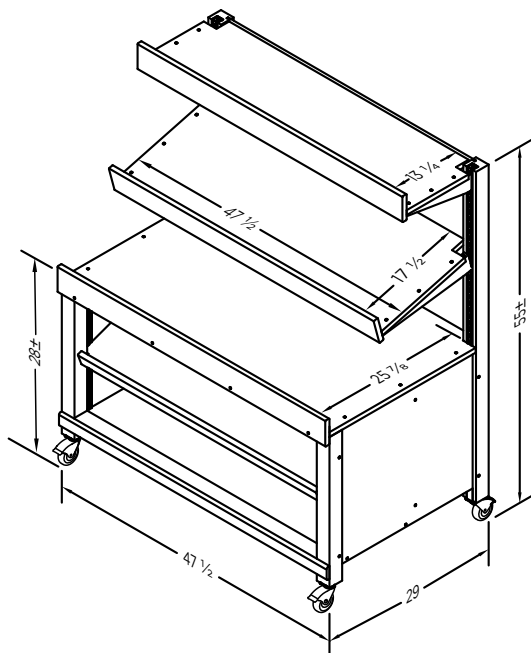

TBFS-002-01B

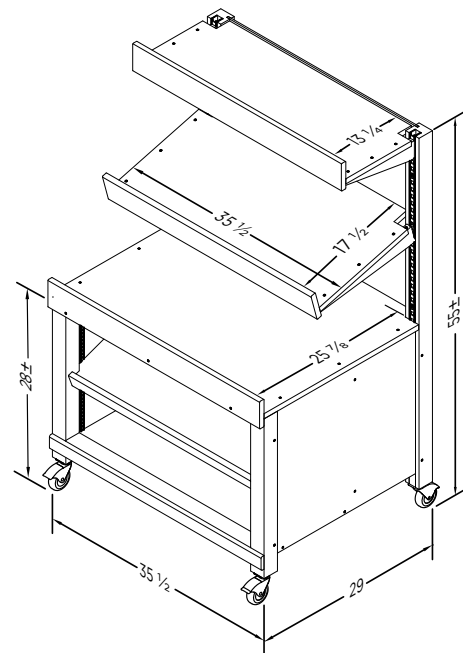

TBFS-002-02B

# TILT-TOP TABLE - WOODEN LEGS



| MODEL        | DESCRIPTION          | LENGTH  | DEPTH   | HEIGHT  |
|--------------|----------------------|---------|---------|---------|
| TBTS-003-01B | Tilt-Top Table - 48" | 47 1/4" | 36 1/2" | 29 1/4" |
| TBTS-004-01B | Tilt-Top Table - 36" | 36"     | 36 1/2" | 31 5/8" |

## FEATURES:

- Solid maple and baltic birch construction
- Heavy duty casters (2 locking)
- Tilt-top merchandising deck
- Removable front product stop
- 2" ABS bumper

## OPTIONS:

- Side product stops
- Acrylic front product stop
- Removable sign holder
- McCue bumper (1" or 2")
- Removable shelves that sit on the tilting deck
- Stain Finishes - see page 68

Note: Information and specifications may change due to engineering improvements.

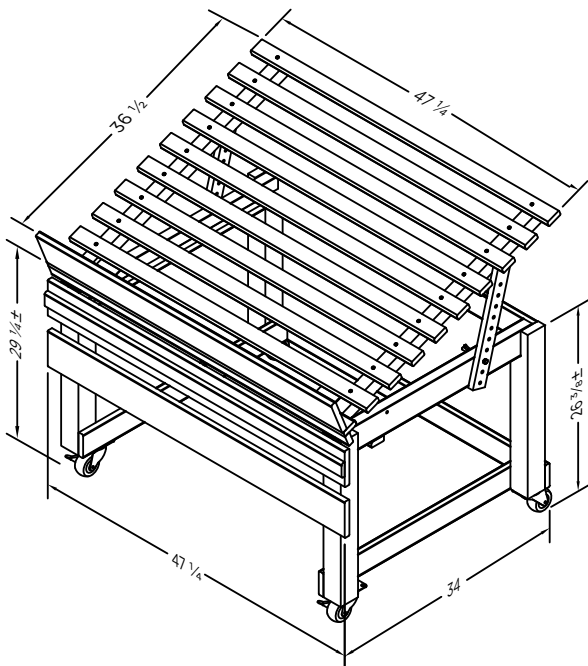

TBTS-003-01B

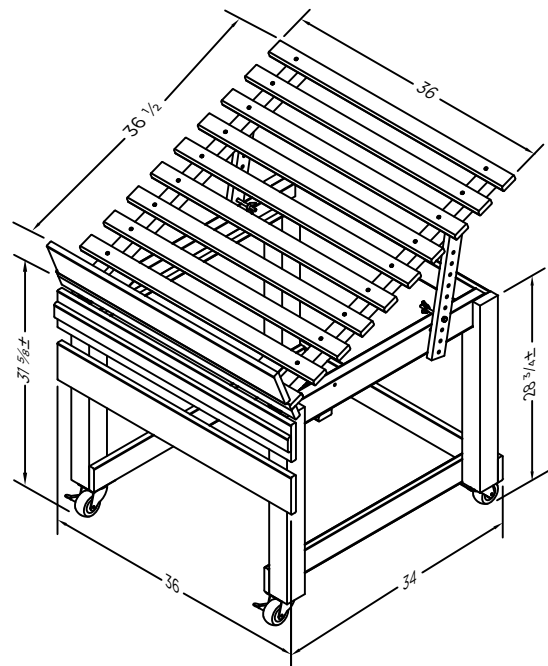

TBTS-004-01B

# TILT-TOP TABLE - METAL LEGS



| MODEL        | DESCRIPTION          | LENGTH | DEPTH | HEIGHT |
|--------------|----------------------|--------|-------|--------|
| TBTS-001-01B | Tilt-Top Table - 48" | 47 ¼"  | 36 ⅛" | 27 ⅜"± |
| TBTS-001-02B | Tilt-Top Table - 36" | 35 ¼"  | 36 ⅛" | 27 ⅜"± |

## FEATURES:

- Solid maple and baltic birch construction
- Adjustable metal legs with locking casters
- Tilt-top merchandising deck
- Pull out drawer
- Removable front product stop
- 2" ABS bumper

## OPTIONS:

- Side product stops
- Acrylic front product stop
- Removable sign holder
- 4' tables also work with pull-out pallet
- Removable shelves that sit on the tilting deck
- McCue bumper (1" or 2")
- Stain Finishes - see page 68

Note: Information and specifications may change due to engineering improvements.

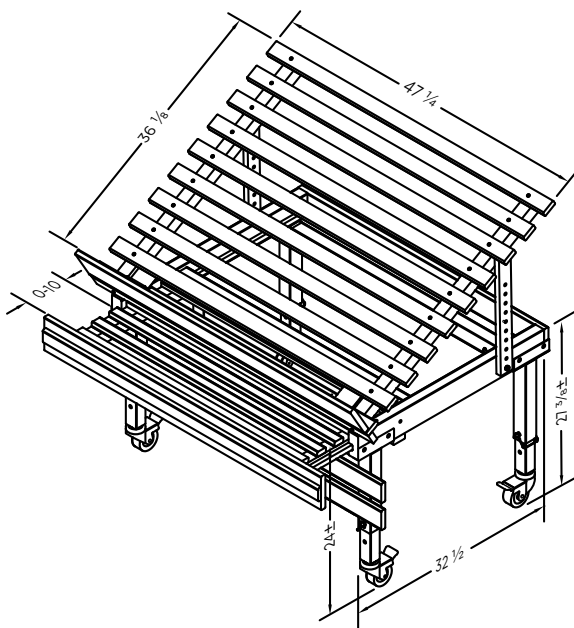

TBTS-001-01B

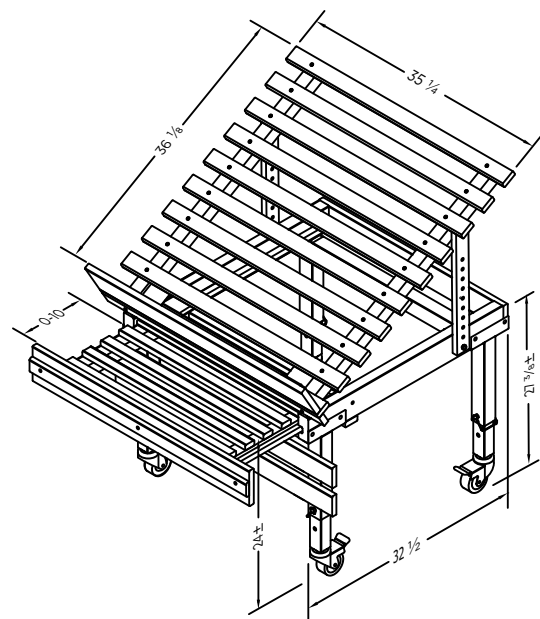

TBTS-001-02B

# TILT-TOP ACCESSORIES - 3FT, 4FT



ACSN-001-02C (3')  
ACSN-001-01C (4')



ACSN-001-02B (3')  
ACSN-001-01B (4')

Front shelf talker

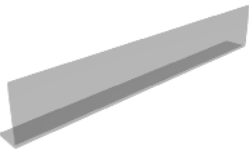

ACPS-001-02A (3')  
ACPS-001-01A (4')



ACPS-002-02A (3')  
ACPS-002-01A (4')

Front Product Stop



ACWG-001-01B

Pull out pallet - designed to only work with TBTS-001-01B (4')



Front Product Stop

Front shelf talker

Pull out pallet

| MODEL          | DESCRIPTION                    | LENGTH  | DEPTH   | HEIGHT |
|----------------|--------------------------------|---------|---------|--------|
| 3' Accessories |                                |         |         |        |
| ACPS-001-02A   | 4x8 Front Product Stop         | 35"     | 8"      | 4"     |
| ACPS-002-02A   | 5x5 Front Product Stop         | 35"     | 5"      | 5"     |
| ACSN-001-02B   | 3 Track Front Lip Signage      | 35 1/4" | -       | 4"     |
| ACSN-001-02C   | Single Track Front Lip Signage | 35 1/4" | -       | 4"     |
| 4' Accessories |                                |         |         |        |
| ACWG-001-01B   | Pull Out Pallet                | 47 1/4" | 26 3/4" | 7"     |
| ACPS-001-01A   | 4x8 Front Product Stop         | 47"     | 8"      | 4"     |
| ACPS-002-01A   | 5x5 Front Product Stop         | 47"     | 5"      | 5"     |
| ACSN-001-01B   | 3 Track Front Lip Signage      | 47 1/4" | -       | 4"     |
| ACSN-001-01C   | Single Track Front Lip Signage | 47 1/4" | -       | 4"     |

## FEATURES:

- Pull out pallet constructed from solid maple and baltic birch
- Pull out pallet designed to only work with TBTS-001-01B as shown on next page
- Front shelf talker constructed from solid maple with metal clips and data strip
- Front product constructed from acrylic

## OPTIONS:

- Acrylic front product stop
  - 5" x 5"
  - 4" x 8"
- Front shelf talker
  - one slot (3 1/4" signage)
  - three slot (1 1/4" signage)
- Stain Finishes - see page 68

Note: Information and specifications may change due to engineering improvements.

# TILT-TOP ACCESSORIES - 3FT AND 4FT



ACPS-003-01A  
Divider



ACPS-004-01B  
Side Product Stops



SHCM-001-01B  
Removable shelf

| MODEL        | DESCRIPTION       | LENGTH  | DEPTH   | HEIGHT |
|--------------|-------------------|---------|---------|--------|
| ACPS-003-01A | Divider           | 36 1/2" | 5"      | 5"     |
| ACPS-004-01B | Side Product Stop | 36 1/2" | 3/4"    | 5"     |
| SHCM-001-01B | Removable Shelf   | 35 1/2" | 10 3/4" | -      |

## FEATURES:

- Divider constructed from solid maple and baltic birch
- Side product stop constructed from solid maple with metal clips
- Removable shelf constructed from solid maple with metal clips
- Divider, side product stops & removable shelf designed to work with both 3' and 4' tilt top tables

- › TBTS-003-01B
- › TBTS-004-01B
- › TBTS-001-01B
- › TBTS-001-02B

## OPTIONS:

- Stain Finishes - see page 68

Note: Information and specifications may change due to engineering improvements.





# HIGHBOYS



| MODEL        | DESCRIPTION      | LENGTH  | DEPTH   | HEIGHT   |
|--------------|------------------|---------|---------|----------|
| SPHB-001-01B | Highboy - Wide   | 23 1/2" | 39"     | 54 1/2"± |
| SPHB-002-01B | Highboy - Narrow | 20"     | 45 1/2" | 56 1/2"± |

## FEATURES:

- Birch/maple plywood and solid maple construction
- Heavy duty casters (2 locking)
- Adjustable angled shelves (angle varies based on angle of back)
- Tilt-top back

## OPTIONS:

- Adjustable flat shelf
- Metal sweep kick
- Stain Finishes - see page 68

Note: Information and specifications may change due to engineering improvements.

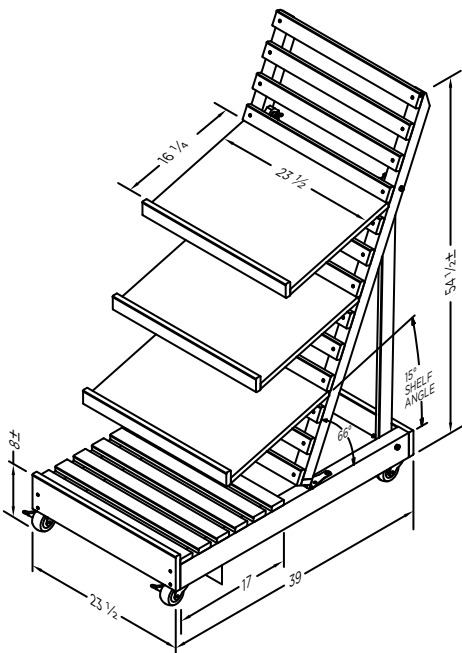

SPHB-001-01B

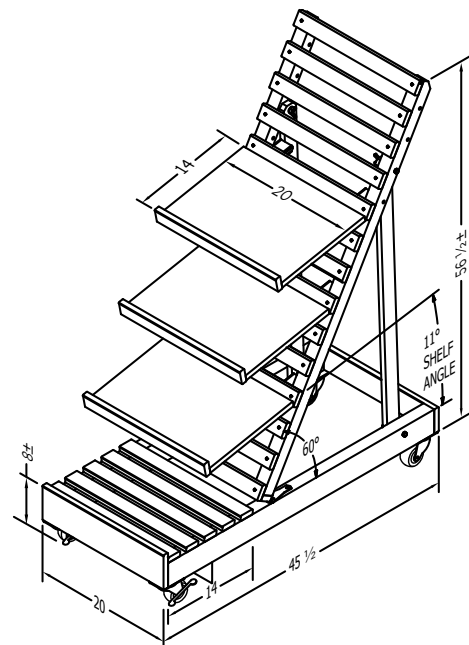

SPHB-002-01B

# BARRELS

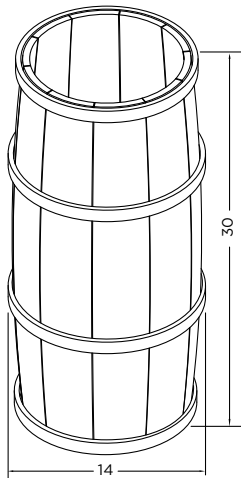

ACBL-001-01A

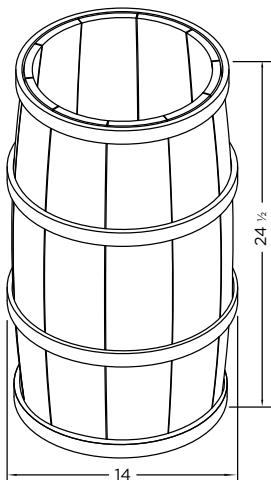

ACBL-002-01A

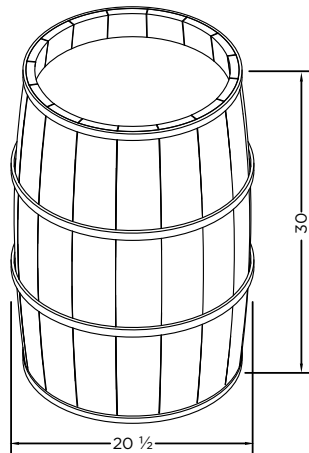

ACBL-003-01A

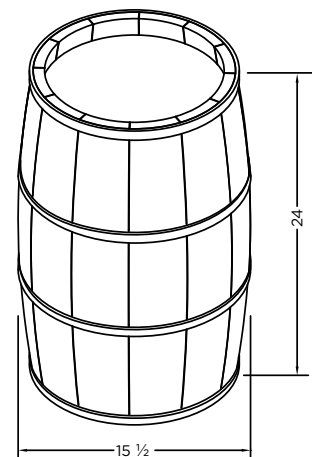

ACBL-004-01A

| MODEL             | DESCRIPTION              | DIAMETER | HEIGHT |
|-------------------|--------------------------|----------|--------|
| ACBL-003-01A      | Barrel - Large           | 20 1/2"Ø | 30"    |
| ACBL-004-01A      | Barrel - Small           | 15 1/2"Ø | 24"    |
| Slim-Line Barrels |                          |          |        |
| ACBL-001-01A      | Slim-Line Barrel - Large | 14"Ø     | 30"    |
| ACBL-002-01A      | Slim-Line Barrel - Small | 14"Ø     | 24"    |

## FEATURES:

- White Cedar construction

## OPTIONS:

- Large barrel
  - Insert (TL 20)
  - Lid (ML 20)
- Large and small slim line barrel
  - Insert (TL 14)
  - Lid (ML 14)
- Scoop holder (FS212)
- Scoop (W110)
- Tether cord with ring (T100/RING)
- Stain Finishes - see page 68

Note: Information and specifications may change due to engineering improvements.

# BARREL ACCESSORIES



| MODEL                                              | DESCRIPTION       |
|----------------------------------------------------|-------------------|
| Designed to work with ACBL-003-01A                 |                   |
| ML20                                               | Lid               |
| TL20                                               | Liner             |
| Designed to work with ACBL-001-01A or ACBL-002-01A |                   |
| ML14                                               | Lid               |
| TL14                                               | Liner             |
| Designed to work with all barrel sizes             |                   |
| W110                                               | Wire Scoop Holder |
| T100/RING                                          | Tether With Ring  |
| FS212                                              | Scoop             |

Note: Information and specifications may change due to engineering improvements.

## LARGE BARREL ACCESSORIES



## SLIM-LINE BARREL ACCESSORIES



# BARREL TOPPERS

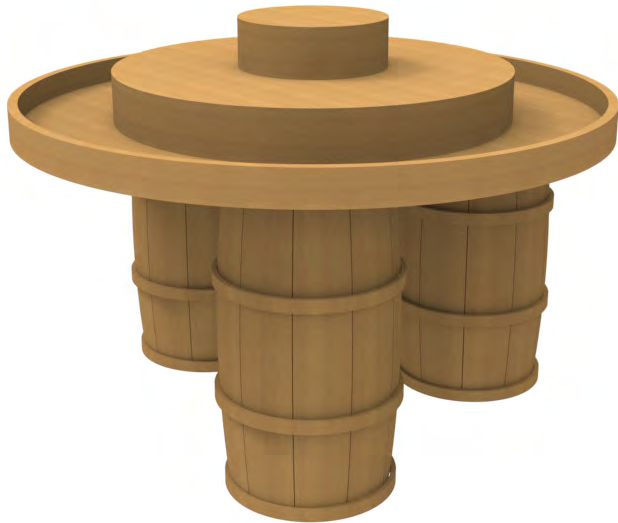

| MODEL        | DESCRIPTION            | DIAMETER | STEPS | HEIGHT |
|--------------|------------------------|----------|-------|--------|
| ACRI-003-01A | Barrel Topper - 3 Tier | 48"Ø     | 3     | 8 ¾"   |
| ACRI-004-01A | Barrel Topper- 2 Tier  | 48"Ø     | 2     | 6 ¾"   |
| ACRI-005-01A | Barrel Topper          | 48"Ø     | 1 ½   | 6 ¾"   |

**FEATURES:**

- Birch/maple plywood and veneer construction

**OPTIONS:**

- Stain Finishes - see page 68

Note: Information and specifications may change due to engineering improvements.

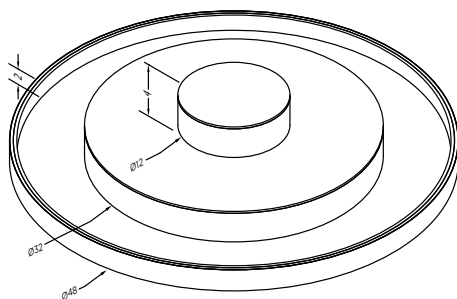

ACRI-003-01A

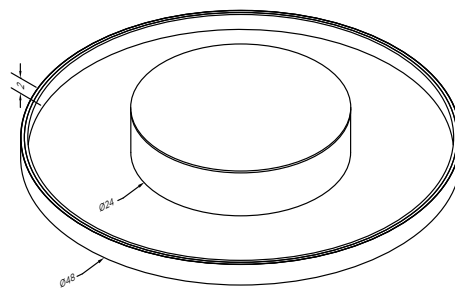

ACRI-004-01A

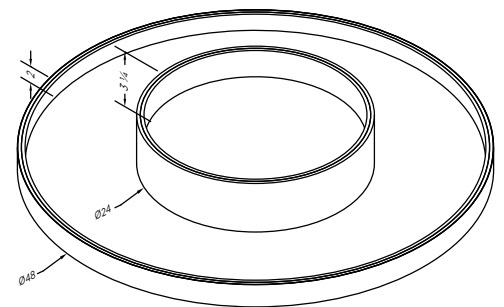

ACRI-005-01A

# BARREL RISER



| MODEL        | DESCRIPTION          | LENGTH  | DEPTH   | HEIGHT |
|--------------|----------------------|---------|---------|--------|
| ACWG-010-01A | Barrel Riser - Large | 19 1/2" | 19 1/2" | 3"     |
| ACWG-011-01A | Barrel Riser - Small | 16"     | 16"     | 3"     |

**FEATURES:**

- Pine board construction

**OPTIONS:**

- Stain Finishes - see page 68

Note: Information and specifications may change due to engineering improvements.

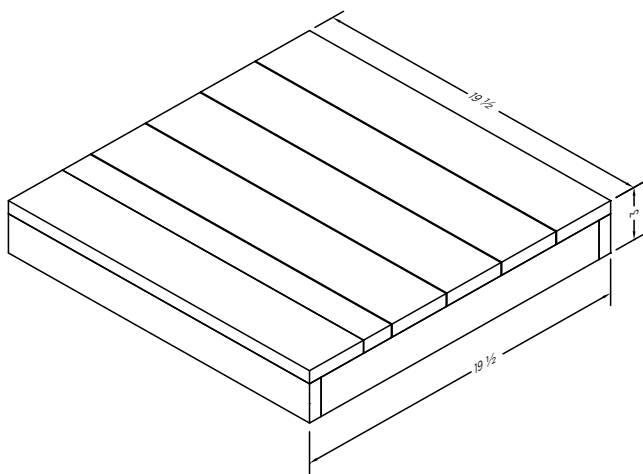

ACWG-010-01A

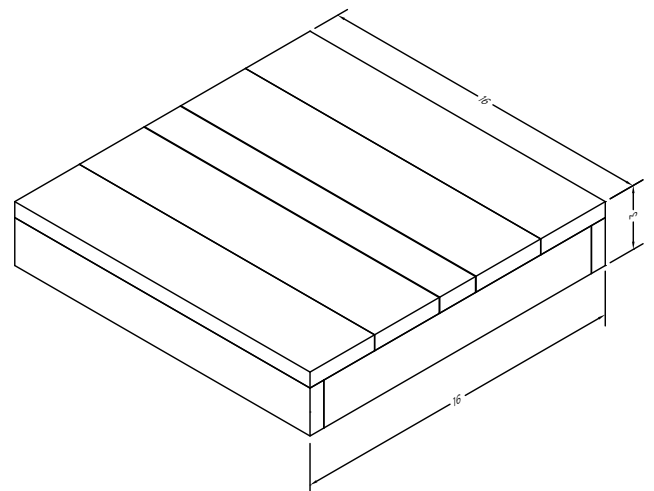

ACWG-011-01A

# CRATES



| MODEL        | DESCRIPTION   | LENGTH  | DEPTH | HEIGHT  |
|--------------|---------------|---------|-------|---------|
| ACCR-001-01A | Crate - Large | 22 1/8" | 14"   | 11 3/4" |
| ACCR-002-01A | Crate - Small | 18 1/2" | 12"   | 6 1/2"  |

## FEATURES:

- Solid spruce and pine construction

## OPTIONS:

- Custom Stencils
- Stain Finishes - see page 68

Note: Information and specifications may change due to engineering improvements.

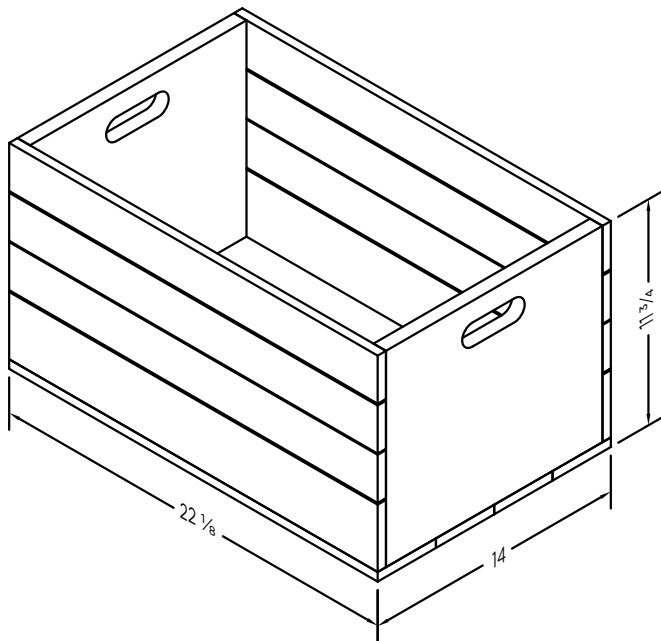

ACCR-001-01A

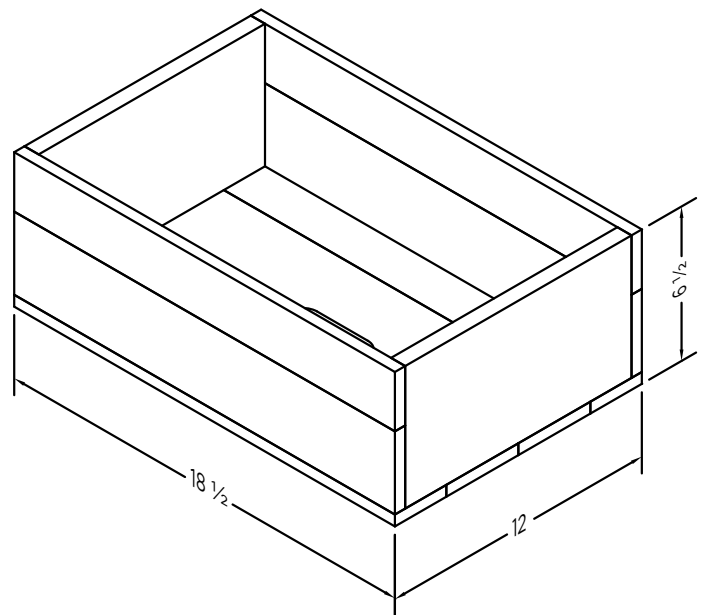

ACCR-002-01A

# ACCESSORIES

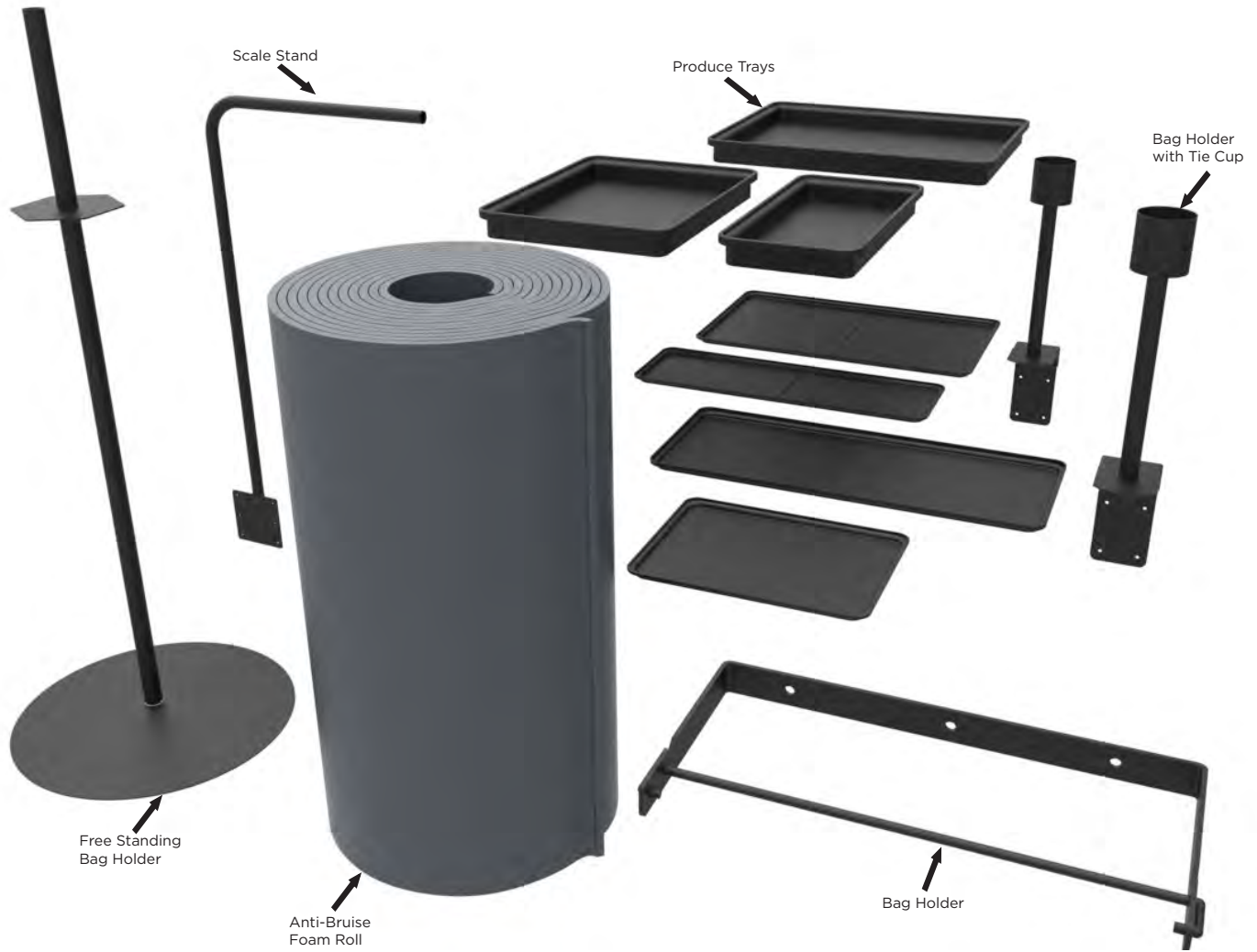

# MARKET TRAY

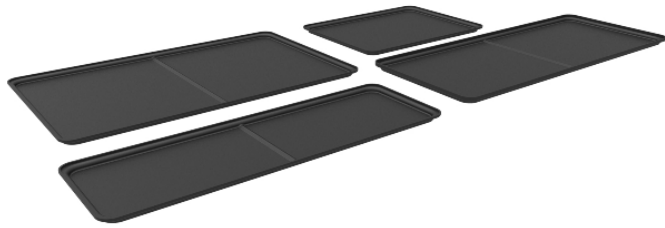

| MODEL        | DESCRIPTION          | LENGTH  | DEPTH   | HEIGHT |
|--------------|----------------------|---------|---------|--------|
| ACTY-003-01A | Market Tray - Double | 29 1/2" | 12"     | 3/4"   |
| ACTY-004-01A | Market Tray - Single | 16 1/4" | 12"     | 5/8"   |
| ACTY-005-01A | Market Tray - Double | 26"     | 15 7/8" | 5/8"   |
| ACTY-006-01A | Market Tray - Double | 26"     | 8 3/8"  | 5/8"   |

## FEATURES:

- Black ABS construction

Note: Information and specifications may change due to engineering improvements.

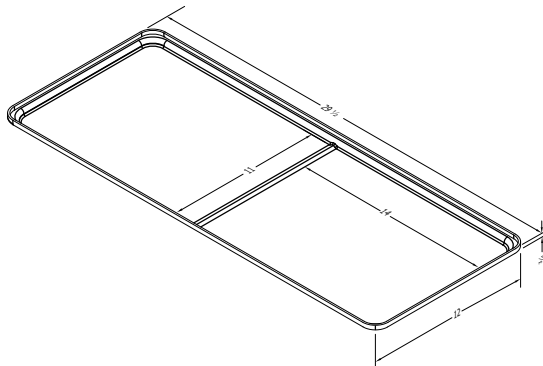

ACTY-003-01A

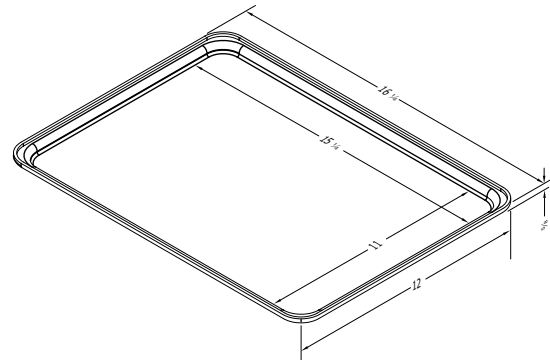

ACTY-004-01A

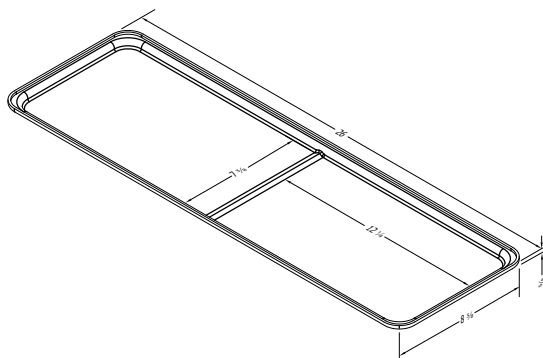

ACTY-005-01A

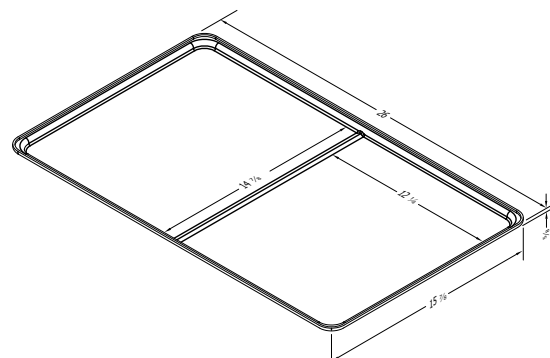

ACTY-006-01A



# PRODUCE TRAY WITH LIP



| MODEL        | DESCRIPTION       | LENGTH | DEPTH | HEIGHT |
|--------------|-------------------|--------|-------|--------|
| ACTY-007-01A | Produce Tray -Lip | 24"    | 30"   | 2 ½"   |
| ACTY-008-01A | Produce Tray -Lip | 24"    | 18"   | 2 ½"   |
| ACTY-009-01A | Produce Tray -Lip | 24"    | 12"   |        |
| ACTY-014-01A | Produce Tray -Lip | 16"    | 12"   | 2 ½"   |

## FEATURES:

- Black ABS construction
- Drainage holes

Note: Information and specifications may change due to engineering improvements.

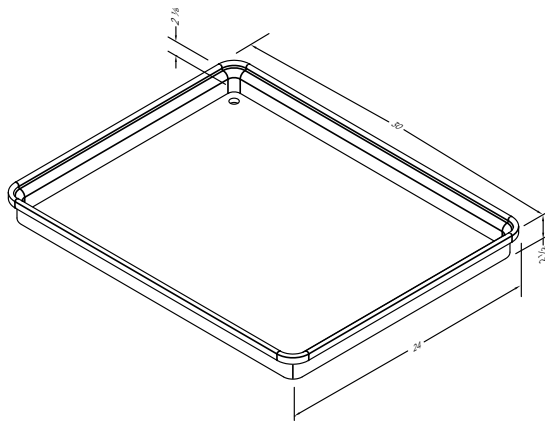

ACTY-007-01A

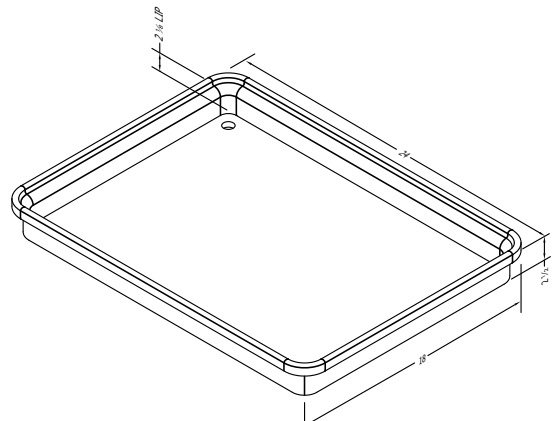

ACTY-008-01A

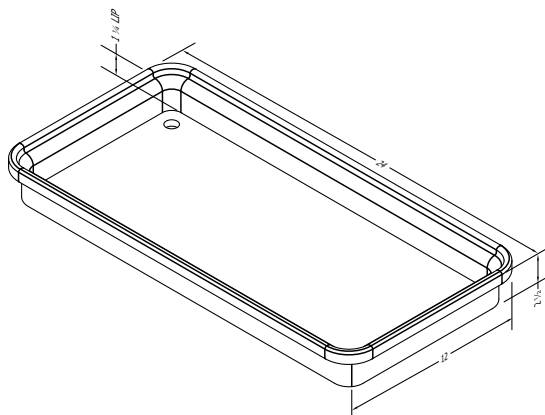

ACTY-009-01A

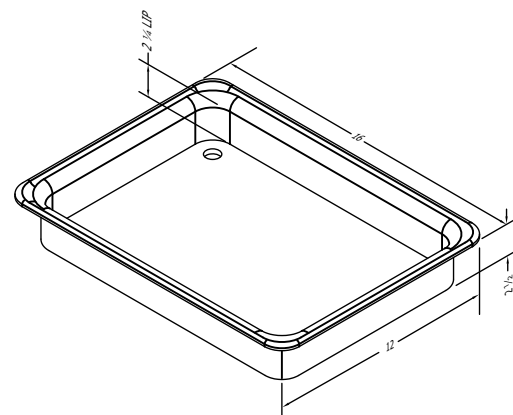

ACTY-014-01A

# PRODUCE TRAY - TWO COMPARTMENT

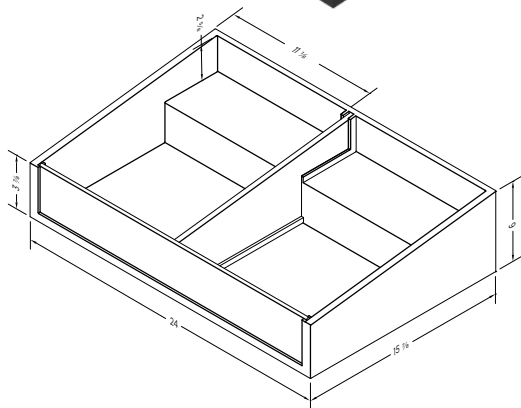
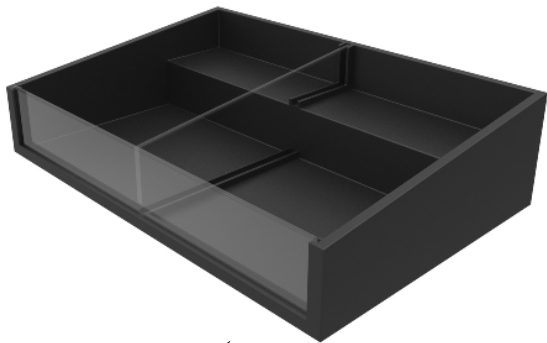

ACTY-015-01A

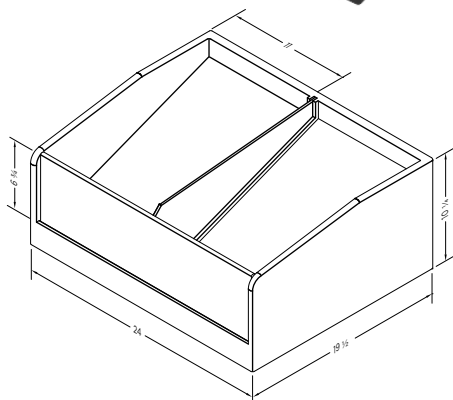
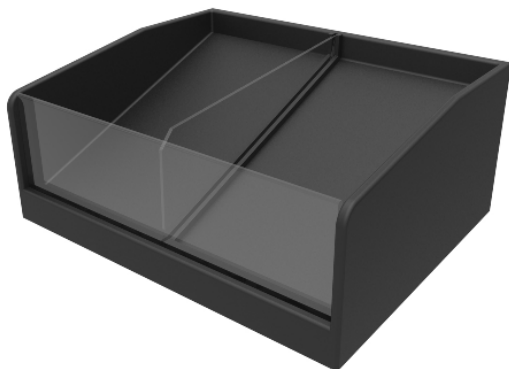

ACTY-016-01A

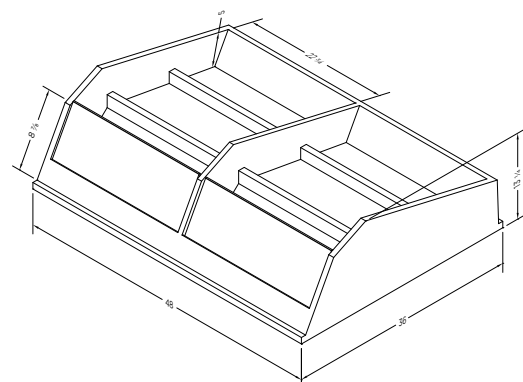
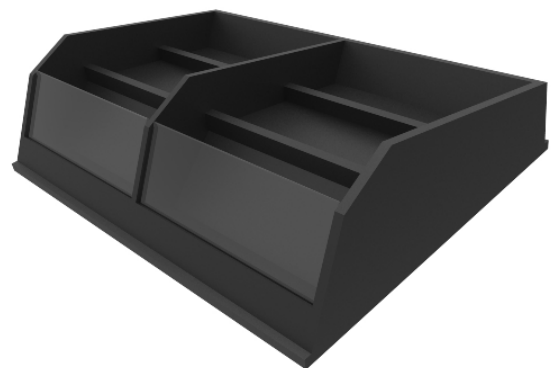

ACTY-017-01A

| MODEL        | DESCRIPTION                            | LENGTH | DEPTH   | HEIGHT  |
|--------------|----------------------------------------|--------|---------|---------|
| ACTY-015-01A | Produce Tray - Tiered, Two Compartment | 24"    | 15 7/8" | 6"      |
| ACTY-016-01A | Produce Tray - Two Compartment         | 24"    | 19 1/2" | 10 1/4" |
| ACTY-017-01A | Produce Tray - Tiered, Two Compartment | 48"    | 36"     | 13 1/4" |

## FEATURES:

- Black ABS construction
- Acrylic front product stop
- ACTY-017-01A Tray designed to work with TBTS-001-01B table

Note: Information and specifications may change due to engineering improvements.

# PRODUCE TRAY



| MODEL        | DESCRIPTION                       | LENGTH  | DEPTH   | HEIGHT |
|--------------|-----------------------------------|---------|---------|--------|
| ACTY-012-01A | Produce Tray - Two Tier           | 35 3/8" | 15 3/4" | 5 1/2" |
| ACTY-013-01A | Anti-bruise foam for ACTY-012-01A |         |         |        |
| ACTY-010-01A | Produce Tray - Two Compartment    | 23 1/8" | 16 1/4" | 2 3/4" |
| ACTY-011-01A | Anti-bruise foam for ACTY-010-01A |         |         |        |

## FEATURES:

- Black ABS construction
- Black anti-bruise closed cell foam
- Trays designed to work with TBTS-005 tables

Note: Information and specifications may change due to engineering improvements.

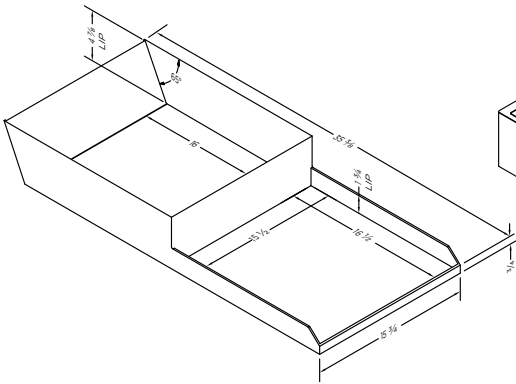

ACTY-012-01A

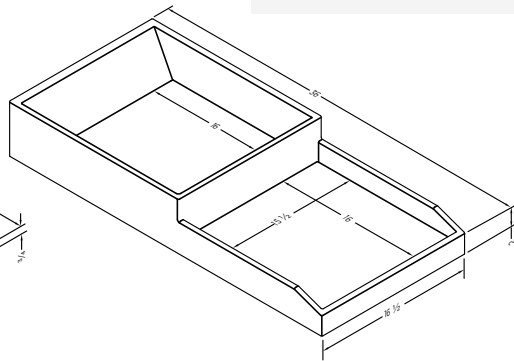

ACTY-013-01A

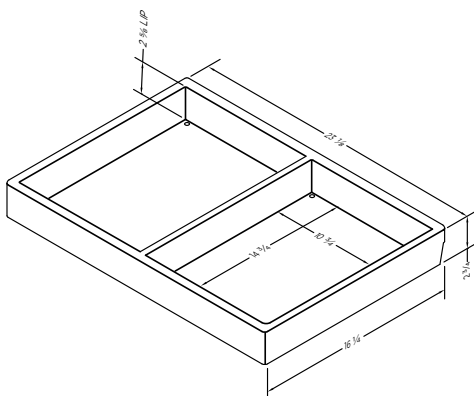
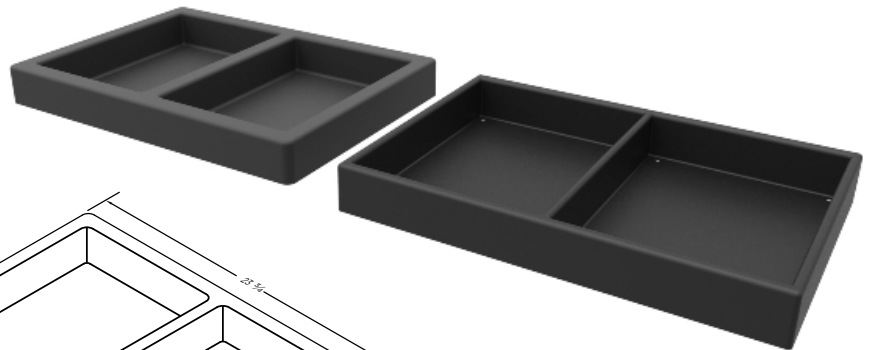

ACTY-010-01A

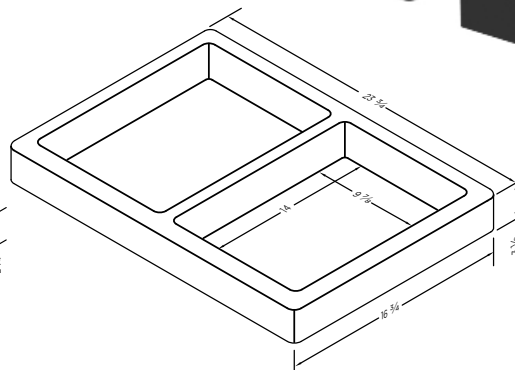

ACTY-011-01A

# BAG HOLDER

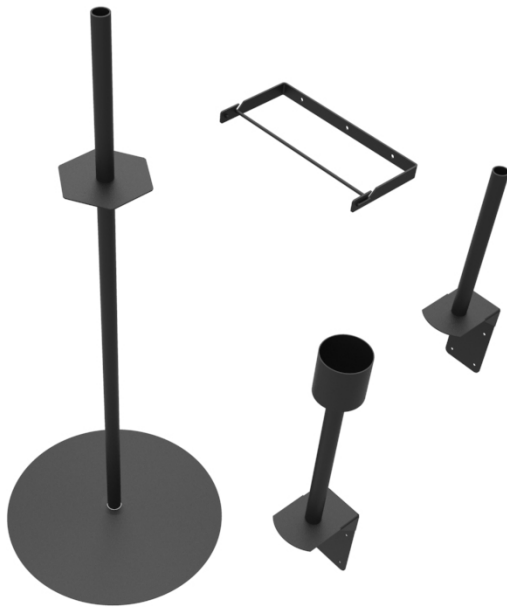

| MODEL         | DESCRIPTION                    | LENGTH  | DEPTH  | HEIGHT  |
|---------------|--------------------------------|---------|--------|---------|
| 182PBAGHOLDER | Horizontal Bag Holder          | 13 1/4" | 6 1/4" | -       |
| ACBH-003-01A  | Free Standing Bag Holder       | 20"Ø    | -      | 50 1/4" |
| ACBH-004-01A  | Screw On Bag Holder            | 4"      | 6"     | 22"     |
| ACBH-004-01B  | Screw On Bag Holder w/ Tie Cup | 4"      | 6"     | 25 1/2" |

## FEATURES:

- Metal construction powder coated black

Note: Information and specifications may change due to engineering improvements.

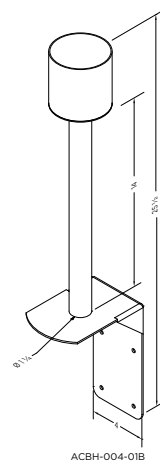
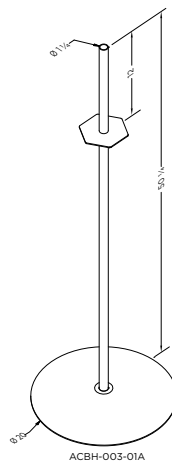
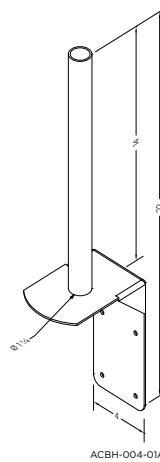
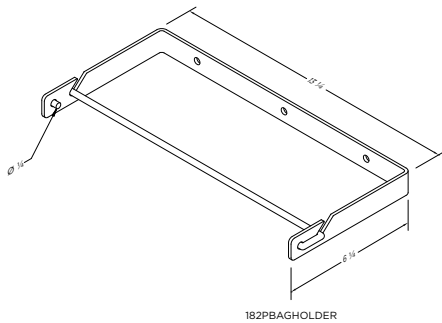

# WIRE SIGN FRAME



| MODEL        | DESCRIPTION         | LENGTH | DEPTH | HEIGHT |
|--------------|---------------------|--------|-------|--------|
| ACSN-003-01A | Sign Cable Post     | 5"     | 1"Ø   | 21"    |
| ACSN-003-01B | Wire Sign Frame Kit | 25'    | -     | 21"    |

## FEATURES:

- Metal construction powder coated black
- Kit comes with sign cable post, wire/rope clip, eye bolt w/ nut, pan head screws & aircraft cable

Note: Information and specifications may change due to engineering improvements.

ACSN-003-01B

Consists of:

Sign cable post (2)

Wire/rope clip (2)

Eye bolt w/ nut (2)

#8 Pan head screws (12)

Aircraft cable (25')

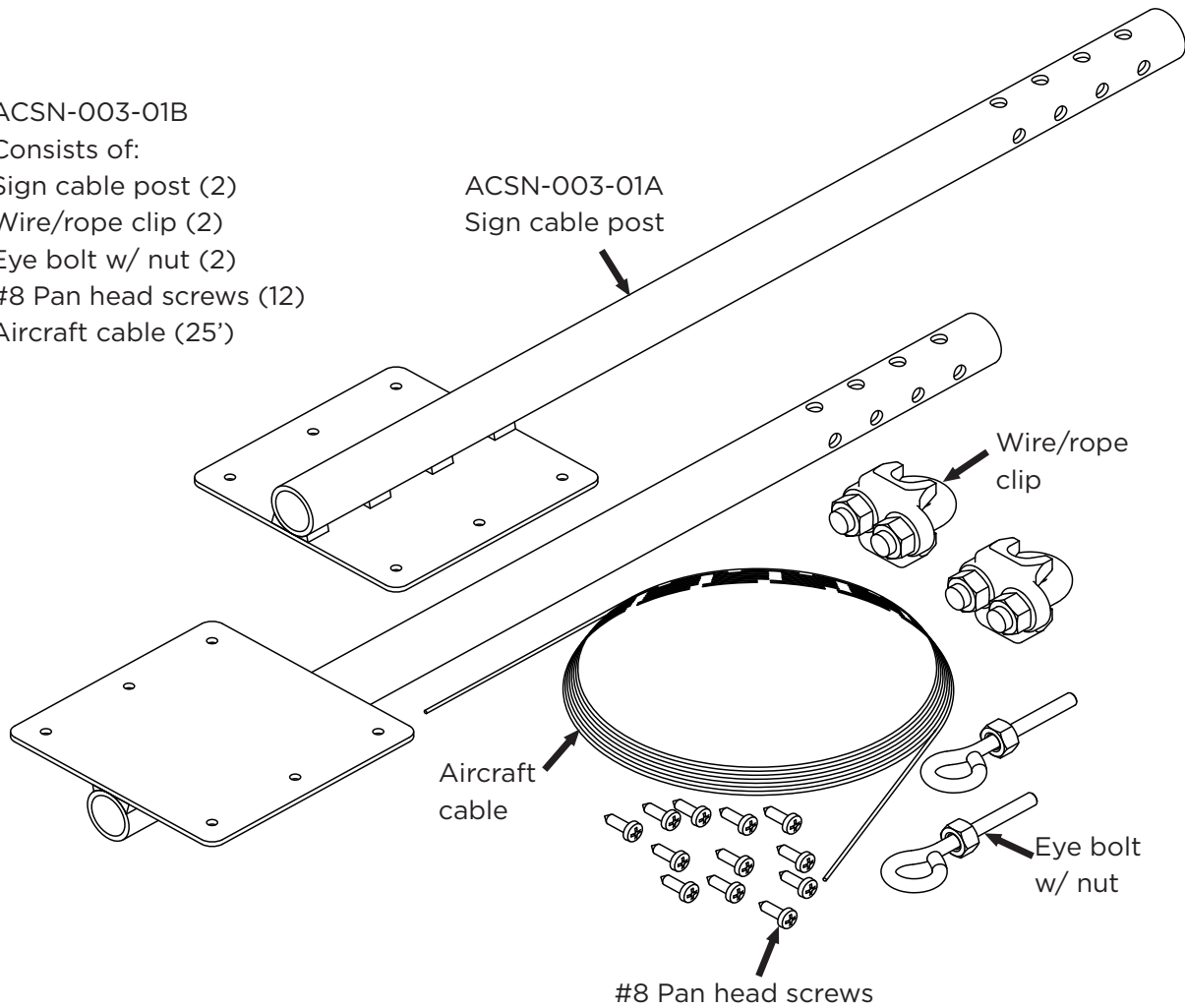

# SCALE HOLDER

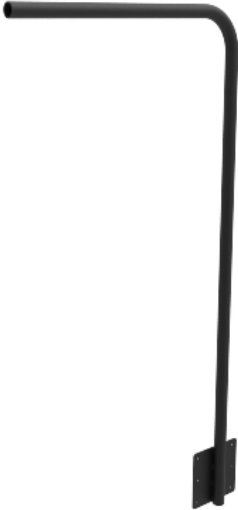

| MODEL        | DESCRIPTION           | LENGTH  | DEPTH | HEIGHT  |
|--------------|-----------------------|---------|-------|---------|
| ACBH-005-01A | Screw On Scale Holder | 20 1/4" | -     | 40 3/8" |

**FEATURES:**

- Metal construction powder coated black

Note: Information and specifications may change due to engineering improvements.

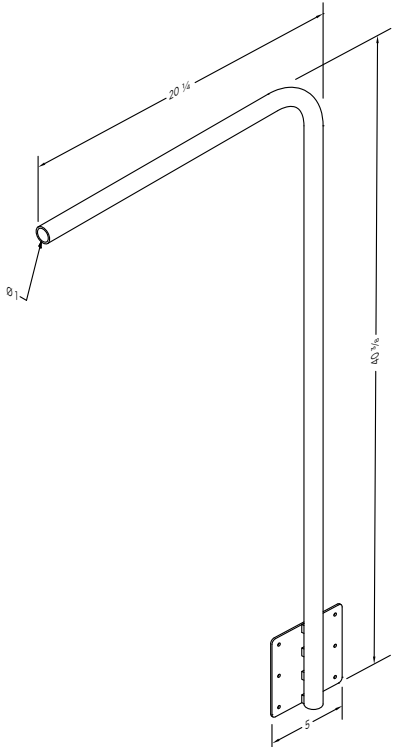

# CLAMP ON SIGN FRAME



| MODEL        | DESCRIPTION         | LENGTH | DEPTH | HEIGHT |
|--------------|---------------------|--------|-------|--------|
| ACSN-002-01B | Clamp On Sign Frame | 36"    | 1 ½"  | 15 ¼"  |

## FEATURES:

- Solid maple construction
- Clamping mechanism to attach sign to rear tilting deck of table
- Sign frame is able to tilt allowing frame to sit vertical with floor
- 3 track Washington Poster
- Works with both 3' & 4' tilt-top table

## OPTIONS:

- Stain Finishes - see page 68

Note: Information and specifications may change due to engineering improvements.

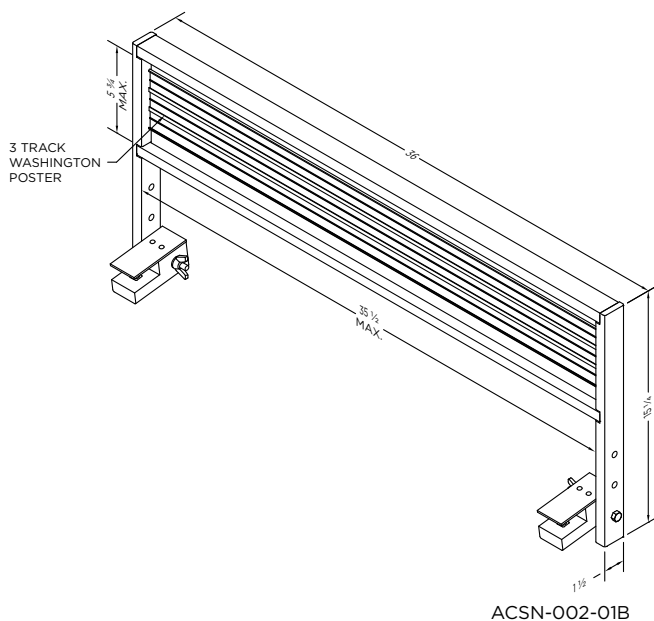

# ANTI-BRUISE FOAM MATTING - ROLL



| MODEL   | DESCRIPTION                     | LENGTH | DEPTH | THICKNESS |
|---------|---------------------------------|--------|-------|-----------|
| CCA-100 | Anti-Bruise Foam Matting - Roll | 100'   | 30"   | 1/2"      |

**FEATURES:**

- 1/2" thick foam matting
- 100ft roll

Note: Information and specifications may change due to engineering improvements.